

8 CHANNEL 2 PAGE COLOR QUAD PROCESSOR

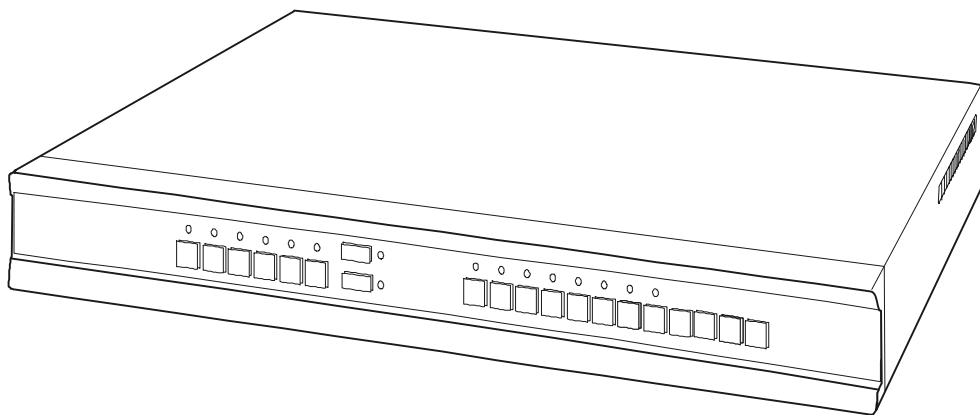

Please read this manual thoroughly before use, and keep it handy for future reference.

ISSUE 1 - MARCH, 2002

THE INFORMATION IN THIS PUBLICATION IS BELIEVED TO BE ACCURATE IN ALL RESPECTS. HOWEVER, WE CANNOT ASSUME RESPONSIBILITY FOR ANY CONSEQUENCES RESULTING FROM THE USE THEREOF. THE INFORMATION CONTAINED HEREIN IS SUBJECT TO CHANGE WITHOUT NOTICE. REVISIONS OR NEW EDITIONS TO THIS PUBLICATION MAY BE ISSUED TO INCORPORATE SUCH CHANGES.

FCC COMPLIANCE STATEMENT

FCC INFORMATION : THIS EQUIPMENT HAS BEEN TESTED AND FOUND TO COMPLY WITH THE LIMITS FOR A CLASS A DIGITAL DEVICE, PURSUANT TO PART 15 OF THE FCC RULES. THESE LIMITS ARE DESIGNED TO PROVIDE REASONABLE PROTECTION AGAINST HARMFUL INTERFERENCE WHEN THE EQUIPMENT IS OPERATED IN A COMMERCIAL ENVIRONMENT. THIS EQUIPMENT GENERATES, USES, AND CAN RADIATE RADIO FREQUENCY ENERGY AND IF NOT INSTALLED AND USED IN ACCORDANCE WITH THE INSTRUCTION MANUAL, MAY CAUSE HARMFUL INTERFERENCE TO RADIO COMMUNICATIONS. OPERATION OF THIS EQUIPMENT IN A RESIDENTIAL AREA IS LIKELY TO CAUSE HARMFUL INTERFERENCE IN WHICH CASE THE USER WILL BE REQUIRED TO CORRECT THE INTERFERENCE AT HIS OWN EXPENCE.

CAUTION : CHANGES OR MODIFICATIONS NOT EXPRESSLY APPROVED BY THE PARTY RESPONSIBLE FOR COMPLIANCE COULD VOID THE USER'S AUTHORITY TO OPERATE THE EQUIPMENT.

THIS CLASS A DIGITAL APPARATUS COMPLIES WITH CANADIAN ICES-003.

CET APPAREIL NUMÉRIQUE DE LA CLASSE A EST CONFORME À LA NORME NMB-003 DU CANADA.

CE COMPLIANCE STATEMENT

WARNING

THIS IS A CLASS A PRODUCT, IN A DOMESTIC ENVIRONMENT THIS PRODUCT MAY CAUSE RADIO INTERFERENCE IN WHICH CASE THE USER MAY BE REQUIRED TO TAKE ADEQUATE MEASURES.

Warnings and Cautions

WARNING

TO REDUCE THE RISK OF FIRE OR ELECTRIC SHOCK, DO NOT EXPOSE THIS PRODUCT TO RAIN OR MOISTURE.

DO NOT INSERT ANY METALLIC OBJECT THROUGH VENTILATION GRILLS.

CAUTION

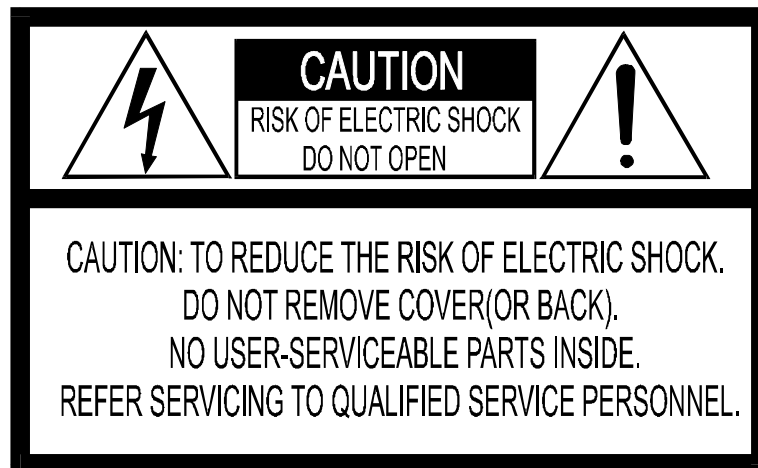

Explanation of Graphical Symbols

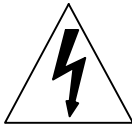

The lightning flash with arrowhead symbol, within an equilateral triangle, is intended to alert the user to the presence of uninsulated “dangerous voltage” within the product’s enclosure that may be of sufficient magnitude to constitute a risk of electric shock to persons.



The exclamation point within an equilateral triangle is intended to alert the user to the presence of important operating and maintenance (servicing) instruction in the literature accompanying the product.

PRECAUTIONS

Safety: Should any liquid or solid object fall into the cabinet, unplug the unit and have it checked by the qualified personnel before operating it any further.

Unplug the unit from the wall outlet if it is not going to be used for several days or more.

To disconnect the cord, pull it out by the plug. Never pull the cord itself.

Allow adequate air circulation to prevent internal heat build-up. Do not place the unit on surfaces (rugs, blankets, etc.) or near materials (curtains, draperies) that may block the ventilation holes.

Installation: Do not install the unit in an extremely hot or humid place or in a place subject to excessive dust or mechanical vibration.

The unit is not designed to waterproof. Exposure to rain or water may damage the unit.

Cleaning: Clean the unit with a slightly damp soft cloth.

Use a mild household detergent. Never use strong solvents such as thinner or benzene as they might damage the finish of the unit.

IMPORTANT SAFEGUARDS

1. READ INSTRUCTIONS – All the safety and operating instructions should be read before the appliance is operated.
2. RETAIN INSTRUCTIONS – The safety and operating instructions should be retained for future reference.
3. CLEANING – Unplug video monitor or equipment from the wall outlet before cleaning. Do not use liquid cleaners or aerosol cleaners. Use a damp cloth for cleaning.
4. ATTACHMENTS – Do not use attachments not recommended by the video monitor or equipment manufacturer as they may result in the risk of fire, electric shock or injury to persons.
5. WATER AND MOISTURE – Do not use video monitor or equipment near water – for example, near a bathtub, washbowl, kitchen sink, laundry tub, in a wet basement, or near a swimming pool, or the like.
6. ACCESSORIES – Do not place video monitor or equipment on an unstable cart, stand or table. The video monitor or equipment may fall, causing serious injury to a child or adult, and serious damage to the equipment. Wall or shelf mounting should follow the manufacturer's instructions, and should use a mounting kit approved by the manufacturer.
- 6A. Video monitor or equipment and cart combinations should be moved with care. Quick stops, excessive force, and uneven surfaces may cause the equipment and cart combination to overturn. 
7. VENTILATION – Slots and openings in the cabinet and the back or bottom are provided for ventilation, and to ensure reliable operation of the video monitor or equipment and to protect it from overheating. These openings must not be blocked or covered. The openings should never be blocked by placing the video monitor or equipment on a bed, sofa, rug, or other similar surface. Video monitor or equipment should never be placed near or over a radiator or heat register. Video monitor or equipment receiver should not be placed in a built-in installation such as a bookcase unless proper ventilation is provided.
8. POWER SOURCES – Video monitor or equipment should be operated only from the type of power source indicated on the marking label. If you are not sure of the type of power supplied to your home, consult your video monitor or equipment dealer or local power company. For video monitor or equipment designed to operate from battery power refer to the operating instructions.
9. GROUNDING OR POLARIZATION – This video monitor may be equipment with a polarized alternating – current line plug (a plug having one blade wider than the other). This plug will fit into the power outlet only one way. This is a safety feature. If you are unable to insert the plug fully into the outlet, try reversing the plug. If the plug should still fail to fit, contact your safety purpose of the polarized plug.

Alternate Warnings – This video monitor is equipment with a three-wire grounding-type plug, a plug having a third (grounding) pin. This plug will only fit into a grounding-type power outlet.

This is a safety feature. If you are unable to insert the plug into the outlet, contact your electrician to replace your obsolete outlet. Do not defeat the safety purpose of the grounding-type plug.

10. POWER CORDS – Do not allow anything to rest on the power cord. Do not locate video monitor or equipment where the cord will be abused by persons walking on it.
 11. HEED WARNINGS – Follow all instructions marked on the video monitor or equipment.
 12. LIGHTNING – For added protection for video monitor or equipment during a lightning storm, or when it is left unattended and unused for long periods of time, unplug it from the wall outlet and disconnect the antenna or cable system. This will prevent damage to the video product due to lightning and power-line surges.
 13. OVERLOADING --Do not overload wall outlets and extension cords as this can result in a risk of fire or electric shock.
 14. OBJECT AND LIQUID ENTRY -- Never push objects of any kind into video monitor or equipment through openings as they may touch dangerous voltage points or short-out parts that could result in a fire or electric shock.
Never spill liquid of any kind on the product.
 15. SERVICING – Do not attempt to service video monitor or equipment yourself as opening or removing covers may expose you to dangerous voltage or other hazards. Refer all servicing to qualified service personnel.
 16. DAMAGE REQUIRING SERVICE – Unplug video monitor or equipment from the wall outlet and refer servicing to qualified service personnel under the following conditions :
 - A. When the power-supply cord or the plug has been damaged.
 - B. If liquid has spilled, or objects have fallen into the video product.
 - C. If the video product has been exposed to rain or water.
 - D. If the video product does not operate normally by following the operating instructions, adjust only those controls that are covered by the operating instructions as an improper adjustment of other controls may result in damage and will often require extensive work by a qualified technician to restore the video product to its normal operation.
 - E. If the video product has been dropped, or the cabinet damaged.
 - F. When the video product exhibits a distinct change in performance – this indicates a need for service.
 17. REPLACEMENT PARTS – When replacement parts are required, be sure the service technician has used replacement parts specified by the manufacturer or that have the same characteristics as the original part. Unauthorized substitutions may result in fire, electric shock or other hazards.
 18. SAFETY CHECK – Upon completion of any service or repairs to this video product, ask the service technician to perform safety checks to determine that the video product is in proper operating condition.
 19. FIELD INSTALLATION – This installation should be made by a qualified service person and should conform to all local codes.
-

TABLE OF CONTENTS

CHAPTER 1. FEATURES	8
Description	8
Features.....	8
CHAPTER 2. FRONT AND REAR PANEL	9
The Front Panel	9
The Rear Panel.....	12
CHAPTER 3. QUAD PROCESSOR FUNCTIONS.....	14
Display Formats	14
VCR Operation.....	18
FREEZE Operation	19
Alarm Mode.....	20
CHAPTER 4. SETUP MODE.....	23
Password Option.....	23
Main Menu Setup	24
Language Setup.....	24
Time And Date Setup.....	25
Camera Setup.....	26
Camera Titles Setup	26
Camera Disable Setup	28
PIP Size Setup.....	30
Alarm Setup.....	30
Alarm Input Setup	31
Video Loss Alarm	33
Alarm Display Setup.....	35
Alarm Time Setup	35
Sequence Setup	36
Picture Adjust.....	38
Configuration.....	39
CHAPTER 5. REMOTE CONTROL.....	44
Overview	44
Remote Command Set.....	45
Remote Connection	46
CHAPTER 6. TECHNICAL SPECIFICATIONS.....	47

CHAPTER 1. FEATURES

Description

The color QUAD is a rear-time 60/50 fields per second color QUAD processor. This stand-alone unit offers advanced features such as zoom on playback of compressed images, sequential switching and time/date/titling overlays.

This color QUAD processor offers a user-friendly on-screen programmable menu. The cameras can be viewed sequentially on alarm, Full screen, or in the QUAD mode.

Features

- Color QUAD Display
- Internal eight camera Sequential Switcher Display
- PIP (Picture In Picture) Display
- Programmable camera skip in sequential mode
- Camera Enable/Disable feature by setup menu
- Quadrants and PIP assign function
- Full Screen Display
- On Screen Display
- Screen Freeze Capability (Quad / PIP Screen, VCR playback, VCR Zoom mode)
- Alarming eight Inputs, N.C or N.O
- Video Loss Alarm
- Video Loss Output (Logic Level Low)
- Two Way VCR Inputs and Outputs (BNC or Y/C)
- Auto-terminating Camera In/Outputs
- Digital Zoom from a QUAD to Full Screen on VCR Playback
- Selectable display on alarm – QUAD or Full Screen.
- Remote Control (RS-485, RS-232)
- User Friendly Programmable Menu
- Rack Mount Kit Included
- Key Lock / Menu Password enabled
- Alarm / Video Loss Count enabled
- Menu Language: English, German, French, Italian, Spanish



CHAPTER 2. FRONT AND REAR PANEL

The Front Panel

KEYBOARD The keyboard provides the primary operator interface. Most operations are one or two button presses. The table on the following page contains a description for each control keys on the keyboard found on the front of this unit. Use *Figure 1* as a reference.

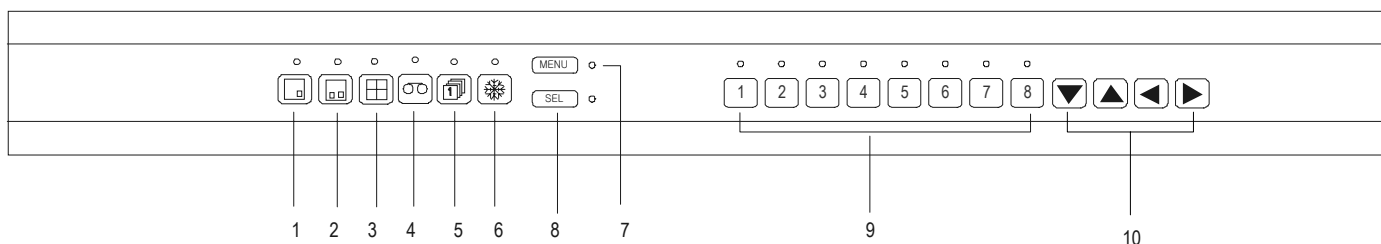
Figure 1. Front





Part	Function	Description
1	PIP1 	Pressing PIP1 displays a full-screen "background" picture with a 1/9 size inset window. The default position of the inset window is the lower-right quadrant. When the unit is in PIP1 mode, the PIP1 LED and the displaying camera LEDs are lit. When alarms occur, pressing PIP1 stops all alarm operation and the screen displays current picture. Note: When the unit is in the VCR playback mode, the PIP1 button is disabled.
2	PIP2 	Pressing PIP2 displays a full-screen "background" picture with two 1/9 size inset windows. The default position of the inset windows is the bottom of the screen. When the unit is in PIP2 mode, the PIP2 LED and the displaying camera LEDs are lit. When alarms occur, pressing PIP2 stops all alarm operation and the screen displays current picture. Note: When the unit is in the VCR playback mode, the PIP2 button is disabled.
3	QUAD 	Pressing QUAD places the unit in the QUAD mode and the QUAD LED and the displaying camera LEDs are lit. This unit has two QUAD pages and pressing QUAD shows the other QUAD page. When alarm occur, pressing QUAD stops all alarm operation and the screen displays current picture. Note: When the unit is in the VCR playback zoom mode, the QUAD button returns to the VCR playback mode.

Continued on next page

The Front Panel, Continued

KEYBOARD CONTROLS (continued)

Part	Function	Description
4	VCR 	<p>The VCR button places the unit into a tape review mode allowing tape playback. To exit the VCR mode, press VCR again. When the unit is in the VCR mode, the VCR LED and the QUAD LED turn on.</p> <p>When alarms occur, pressing VCR stops all alarm operation and the screen displays current picture.</p>
5	SEQ 	<p>Pressing SEQ places the unit in the sequential switching mode and the SEQ LED is lit. Pressing SEQ again exits the sequential switching mode. The current displaying camera LEDs turn on and a small "s" character is shown on the lower-right of the screen when the unit is in this mode.</p> <p>When alarms occur, pressing SEQ stops all alarm operation and the screen displays current picture.</p> <p>Note: When the unit is in the VCR Playback mode, the SEQ button is disable.</p>
6	FREEZE 	<p>Pressing FREEZE stops the current picture of PIP, QUAD, VCR playback, or VCR Zoom screen. Pressing FREEZE again unfreezes the image. When the unit is in the FREEZE mode, the "F" characters blinks beside to the titles of frozen cameras.</p> <p>When alarms occur, pressing this button stops all alarm operation and the screen displays current picture.</p>
7	MENU	<p>Pressing MENU places the unit in the programmable Menu Setup mode. When in Menu Setup mode, pressing this button is to exit this mode or to go up to the upper Menu from Sub Menu. In the Menu Setup mode, the Menu LED is lit and any alarm can't be detected.</p> <p>When alarms occur, pressing MENU stops all alarm operation and the screen goes to the Menu Setup mode.</p>

Continued on next page

The Front Panel, Continued

KEYBOARD CONTROLS (continued)

Part	Function	Description
8	SEL (SELECT)	When the unit is Menu Setup mode, the button acts as a SET button. When alarms occur, pressing SEL stops all alarm operation and the screen displays current picture Also, the SEL button enables secondary functions with particular buttons: ► SWAP: In the PIP mode, pressing the PIP after pressing SEL performs the swap function. ► Camera Assign: In the PIP or QUAD mode, pressing camera button after pressing SEL assigns cameras to PIP or QUAD pictures.
9	CAMERA 1 ~ 8	The all camera buttons will: 1) Display the camera in the Full screen mode, 2) Unfreeze or freeze the image in freeze mode in the QUAD or PIP mode. And only Camera 1 to 4 buttons will zoom the quadrant image to Full screen when the unit is in a VCR playback mode. When alarms occur, pressing the camera button stops all alarm operation and the screen displays current picture.
10	ARROW 	The arrow buttons act as the DOWN, UP, LEFT, and RIGHT buttons in Menu Setup mode, respectively. When alarms occur, pressing any arrow button stops all alarm operation and the screen displays current picture.

The Rear Panel

CONNECTIONS The table below contains a description for each connection on the back of the quad processor. Use *Figure 2* as a reference.

Figure 2. Back

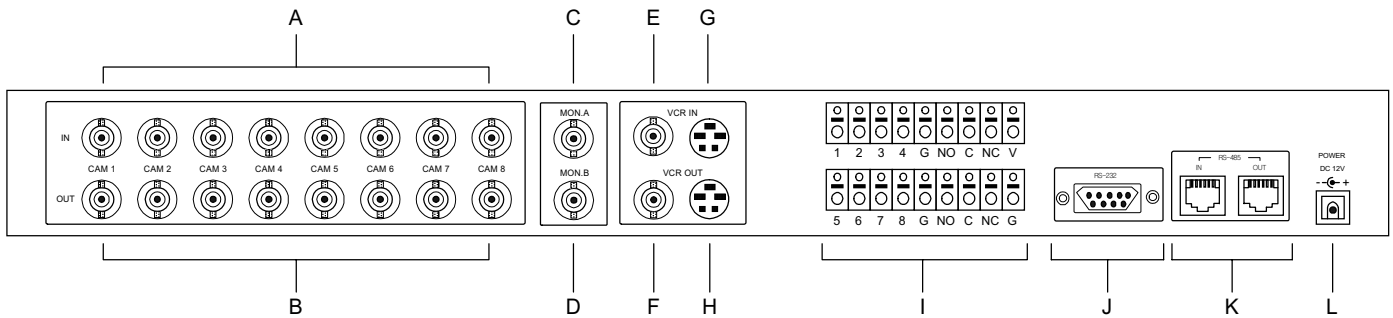

Part	Label	Function
A	Camera In	Accepts the inputs from cameras.
B	Camera Out	Looping outputs for use with auxiliary equipment.
C	MON.A	This is the call output that can display Full screen, QUAD, or PIP images. Alarmed and zoomed images appear on this screen.
D	MON.B	Outputs QUAD or PIP screen display normally, or Full display on alarm.
E	VCR IN BNC	Inputs from VCR for reviewing the tape and allows use of zoom feature.
F	VCR OUT BNC	Buffered MON.B for use with a VCR for recording.
G	VCR IN Y/C	Same as VCR IN BNC.
H	VCR OUT Y/C	Same as VCR OUT BNC.
I	Alarm In	These are alarming inputs, Normally Open or Closed, selectable in programming setup mode.
	Alarm Out	These are Form C dry relay contacts.
J	RS-232	9 pin D-Sub(female) for RS-232 remote control.
K	RS-485	RJ-45 8 pin modular jacks for RS-485 remote control.
K	POWER	This 2.1mm pin jack accepts 12V dc at 1.5A. The center pin is positive.

Continued on next page

The Rear Panel, Continued

CONNECTIONS (continued)

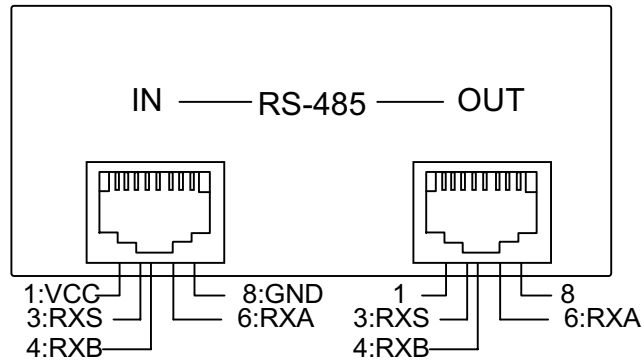

REMOTE CONNECTOR PIN ASSIGNMENT

RS-232	PIN ASSIGNMENT	RS-485	PIN ASSIGNMENT
1	NO CONNECTION	1	VCC
2	RS-232 RX	2	NO CONNECTION
3	RS-232 TX	3	RXS
4	NO CONNECTION	4	RXB
5	GROUND	5	NO CONNECTION
6	NO CONNECTION	6	RXA
7	NO CONNECTION	7	NO CONNECTION
8	NO CONNECTION	8	GND
9	NO CONNECTION		

CHAPTER 3. QUAD PROCESSOR FUNCTIONS

Display Formats

PIP1 DISPLAY Pressing PIP1 button will display a full-screen “background” picture with a 1/9 size screen inset. PIP1 LED and the displaying camera LEDs are lit. The default display format is a Full screen of Camera 1 with a lower-right 1/9 size Camera 2 inset. The unit remembers and shows the last PIP1 screen format, if any display mode change happened. Use the following table contents as a guide for the possible actions in the PIP1 mode.

Button(s)	Action
PIP1	Press PIP1 again to move the Inset Screen position to the next position.
SEL + CAM (1-8)	<p>Camera Assign mode:</p> <p>If SEL button is pressed, the SEL LED is lit and when a camera button is pressed, the “ASSIGN MODE” message is displayed on the screen. The first pressed camera number button is assigned to the background (main) picture, then its title is displayed and its LED turns on. Press another camera number button except already displaying camera to assign the inset picture (sub), then its title is displayed and its LED is lit. The SEL LED indicator turns off and the new PIP1 screen is displayed.</p> <p>Note: Pressing SEL before the camera assign mode finishes will not change PIP1 screen display format.</p>
SEQ	<p>Sub Sequence mode:</p> <p>Press SEQ to sequence the inset picture and the current inset camera LED and SEQ LED turn on. Press SEQ again to stop the sequence and the SEQ LED turns off. In this mode, cameras not already displayed can be sequenced with a black screen.</p>
SEL + SEQ	<p>Main Sequence mode:</p> <p>Press SEL then SEL LED is lit. Press SEQ to sequence the main picture. Then the changing main camera LED and SEQ LED are lit. Press SEQ again to stop the sequence and the SEQ LED turns off. In this mode, cameras not already displayed can be sequenced with a black screen.</p>

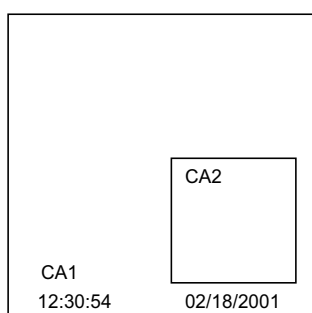

POSITION 1

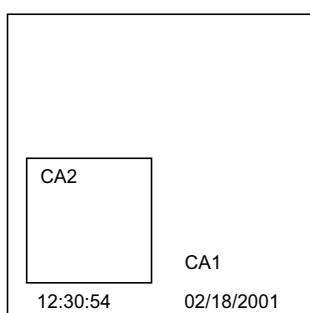

POSITION 2

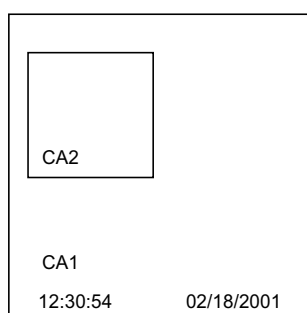

POSITION 3

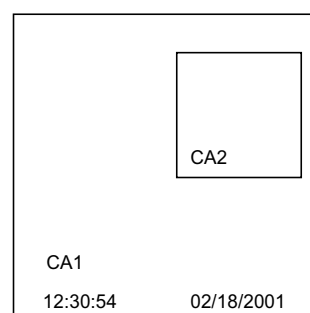

POSITION 4

PIP1 Display, Continued

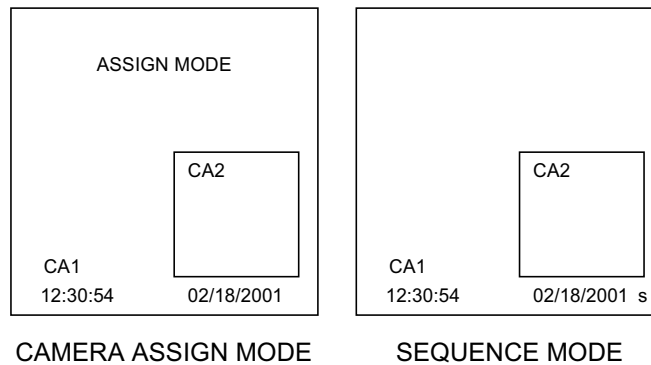

PIP2 DISPLAY

Pressing PIP2 button will display a full-screen “background” picture with two 1/9 size screen inset windows. The PIP2 LED and the displaying camera LEDs are lit. The default display format is a Full screen of Camera 1 with two 1/9 size Camera 2, 3 inset windows on bottom. The unit remembers and shows the last PIP2 screen format, if any display mode change happened. Use the following table contents as a guide for the possible actions in the PIP2 mode.

Button(s)	Action
PIP2	Press PIP2 again to move the inset camera to the next position.
SEL + CAM (1-8)	<p>Camera assign mode:</p> <p>Press SEL to assign cameras. The SEL LED is lit and when a camera button is pressed, “ ASSIGN MODE” message is displayed on the screen. The first pressed camera number button is assigned to the background (main) picture, then its title is displayed and its LED turns on. Press remaining two camera number buttons except already displaying camera to assign the inset (sub) pictures. Then the titles of the selected cameras are displayed and the SEL LED indicator turns off and the new-assigned PIP2 screen is displayed.</p> <p>Note: Pressing SEL before the camera assign mode finishes goes to the previous screen with no change.</p>
SEQ	<p>Sub Sequence mode:</p> <p>Press SEQ to start the sequence of the lower-right inset camera and then the LED of the current inset camera and SEQ LED turn on. Press SEQ again to stop the sequence and the SEQ LED turns off. In this mode, cameras not already displayed can be sequenced.</p>
SEL + SEQ	<p>Main sequence mode:</p> <p>Press SEL then SEL LED is lit. Press SEQ to start the sequence of the main camera and then the LED of the current main camera and SEQ LED turn on. Press SEQ again to stop the sequence and the SEQ LED turns off. In this mode, cameras not already displayed can be sequenced.</p>

PIP2 Display, Continued

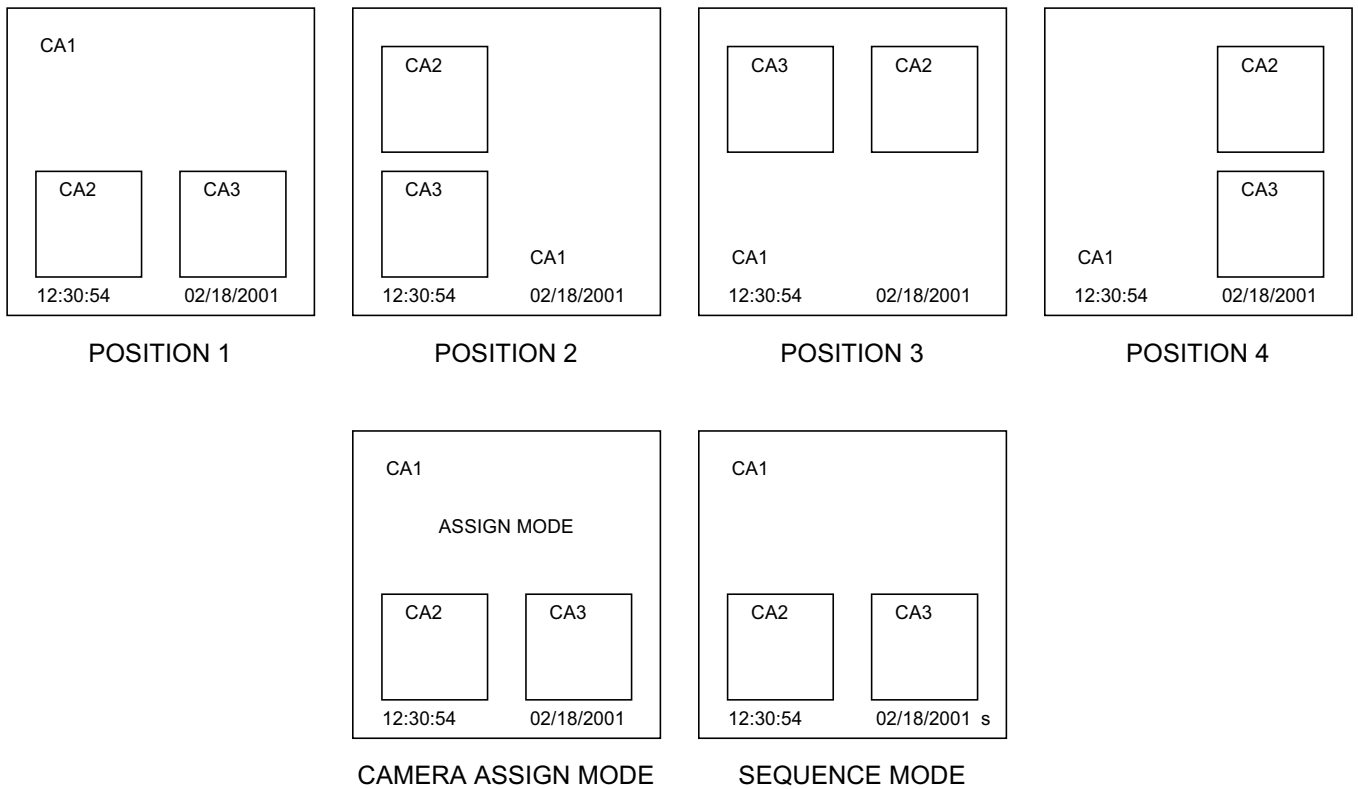

QUAD DISPLAY

Pressing QUAD button displays a QUAD screen with four camera pictures. Black background displays for not installed or disabled cameras. The LEDs of the installed and enabled cameras and QUAD LED are lit. Use the following table as a guide for the actions possible in the QUAD mode.

Button(s)	Action
QUAD	<p>Press QUAD again to change QUAD page.</p> <p>The default page setups are as follows:</p> <ul style="list-style-type: none"> ● Page 1 = (CA1, CA2, CA3, CA4) Page 2 = (CA5, CA6, CA7, CA8)
SEL + CAM (1-8)	<p>Camera assign mode:</p> <p>Press SEL to assign cameras. The SEL LED is lit and when a camera button is pressed, the "ASSIGN MODE P1" message for page 1 (or "ASSIGN MODE P2" for page 2) is displayed on the screen. The first pressed camera number button is assigned to the first quadrant, then its title is displayed and its LED turns on. Press the remaining three camera numbers for the remaining three quadrants in order of display except already displayed cameras. Then the SEL LED indicator turns off and the new-assigned QUAD page is displayed.</p> <p>Note: Pressing SEL before the camera assign mode finishes goes to the previous screen with no change.</p>

SEQ	<p>Quadrant sequence mode :</p> <p>Press SEQ to start the sequence of the lower-right quadrant camera and the LED of the current quadrant camera and SEQ LED turn on. Press SEQ again to stop the sequence and the SEQ LED turns off. In this mode, cameras not already displayed can be sequenced.</p>
SEL + SEQ	<p>Page sequence mode:</p> <p>Press SEL then SEL LED is lit. Press SEQ to sequence a page. Then SEQ LED is lit. Press SEQ again to stop the sequence and the SEQ LED turns off.</p>

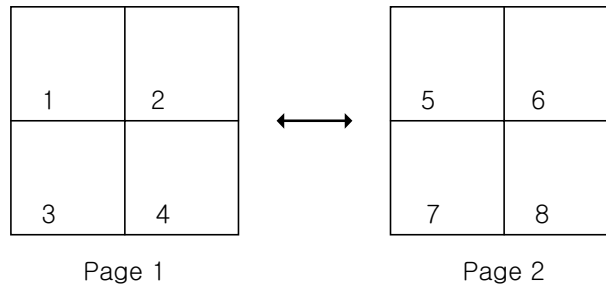

**FULL
SCREEN
DISPLAY**

Press any camera number button to change the display to the Full screen display mode of the camera. In this mode, the current displaying camera LED is lit.

Button(s)	Action
CAM (1-8)	<p>Press camera number button to change the display to the Full screen display mode of the camera.</p> <p>Note: The blue screen is displayed for the camera with no video signal.</p>
SEQ	<p>Press SEQ to start the sequence of the camera and the camera LED and SEQ LED turns on. Press SEQ again to stop the sequence and the SEQ LED turns off.</p>

**SEQ
DISPLAY**

Pressing SEQ sequences the cameras in order set in the Menu Setup. The displayed camera LED and SEQ LED are lit and a small “s” character is displayed on the screen. If the dwell time in the Menu Setup is set to more than one second for any uninstalled camera or any disabled camera, the camera sequences with a black background in QUAD/PIP mode or with a blue background in Full-screen mode. If the dwell time is set to OFF for any camera, the camera will be skipped in the sequence even if installed to the system and enabled. The dwell time for each camera can be set individually and sequence order can be set in the Menu Setup. Pressing SEQ again stops the sequential switching mode.

VCR Operation

The VCR mode allows you to view the video playing back the VCR.

VCR PLAYBACK

After you pressed the PLAY button of the VCR, Pressing the VCR button displays the VCR playback. In this mode, the VCR LED and QUAD LED are lit. When the unit is in VCR playback mode and frozen screen, FREEZE LED is lit and QUAD LED is blinking.

The VCR Input is either BNC or Y/C. The VCR input (BNC, Y/C) can be set in the CONFIGURE SETUP menu.

VCR OUTPUT

The VCR signal goes to both the VCR BNC Output and the VCR Y/C Output.

The VCR output is same as the MON.A output when the display mode is a QUAD or PIP mode.

And the VCR output is the last QUAD or PIP display mode when the MON.A output is a Full screen display.

VCR ZOOM DISPLAY

The zoom display mode is enable when the unit is only in the VCR playback mode. The zoom is a 2X zoom that expands one quarter of the screen to the Full screen. Pressing the camera button 1 ~ 4 places the unit into a zoomed picture and turns on the camera number LED and displays a character “Z” on the top of the screen.

Note: When the unit is in the VCR Loop Through, the VCR ZOOM mode is disable and pressing camera buttons places the unit in the Full Screen Mode of corresponding camera.

Note: When the unit is in the FREEZE mode or the VCR ZOOM mode, the MON.B output signal is same as MON.A output signal.

Note: Some brands of VCRs don't generate the standard video format signal in Time-Laps Playback mode correctly, resulting in an abnormal picture on the top portion of the screen.

Note: There may be some signal-noise visible on your screen when the VCR stops playing a tape while the PLAYBACK ZOOM option is ON. This is normal as there is no signal present.

Button(s)	Action
CAM (1 - 4)	Press a camera number button 1 ~ 4 to expand one quarter of the screen to Full screen and then the camera LED turns on.
QUAD	Press QUAD button to exit the ZOOM mode and to go to the original picture screen. Then the camera number LED turns off and QUAD LED turns on.
FREEZE	Press FREEZE button to freeze current zoomed picture and display a blanking character “F” on the top of the screen. Then the FREEZE LED is lit.

FREEZE Operation

FREEZE DISPLAY Pressing FREEZE freezes the screen of the QUAD, PIP, or VCR playback mode. When the unit is freeze mode, FREEZE LED is lit and the frozen camera LEDs blink. And the blinking "F" character is displayed and the image is frozen on the screen until the FREEZE button is pressed again or the corresponding camera button is pressed.

Note: In the QUAD/PIP mode, if FREEZE is pressed, the VCR and MON.B outputs are frozen.

Note: In the Full screen mode, FREEZE function is disabled.

MODE	Button(s)	Action
QUAD FROZEN	CAM (1-8)	Press the camera button of the frozen camera to live the frozen camera, then the camera LED turns ON. To freeze the camera again, press the camera button again, then the camera LED blinks. If all cameras are unfrozen by pressing the camera buttons, the unit exits the Freeze mode.
	FREEZE	Press FREEZE to exit the FREEZE mode.
PIP FROZEN	CAM (1-8)	Press the camera button of the frozen camera to live the frozen a camera, then the camera LED turns OFF. To freeze the camera again, press the camera button again, then the camera LED blinks. If all cameras are unfrozen by pressing the camera buttons, the unit exits the Freeze mode. Pressing the camera button not assigned in PIP mode exits FREEZE mode and the unit goes to the corresponding camera in the full screen.
	FREEZE	Pressing FREEZE exits the FREEZE mode.
VCR FROZEN	FREEZE	Pressing FREEZE exits the FREEZE mode.
VCR ZOOM FROZEN	FREEZE	Pressing FREEZE exits the FREEZE mode.
	QUAD	Pressing QUAD exits the FREEZE mode and ZOOM mode.

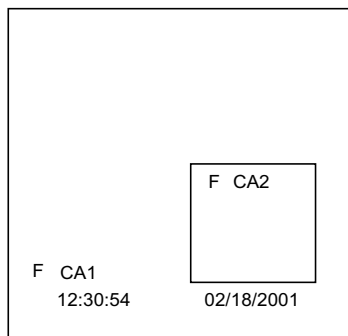

PIP1 DISPLAY MODE

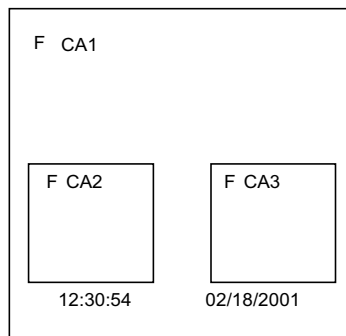

PIP2 DISPLAY MODE

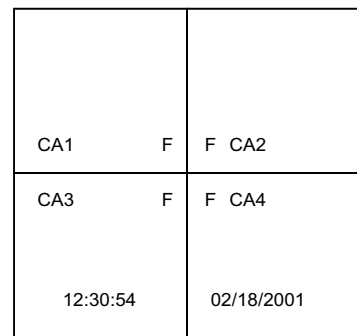

QUAD DISPLAY MODE

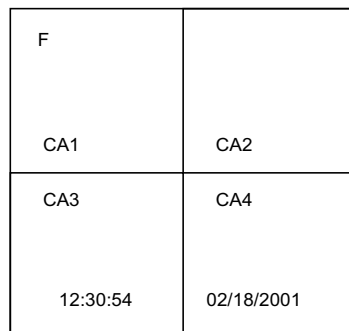

VCR PLAYBACK MODE

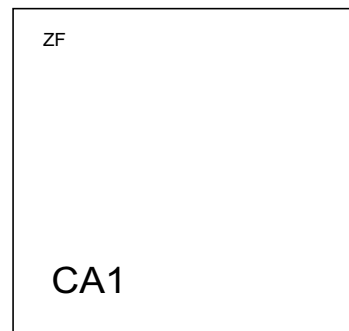

VCR ZOOM DISPLAY MODE

Alarm Mode

OVERVIEW The color QUAD has several alarm functions, including a single alarm, multiple alarm, VCR mode alarm and Video loss alarm. Each of these alarms will be explained in this section.

- SINGLE ALARM AND MULTIPLE ALARMS** When alarms occur, the following actions are carried out.
- The LED indicators of the alarmed cameras blink twice per second.
 - The alarm buzzer sounds if enabled.
 - The alarm relays are energized if enabled.
 - The blinking character "A" is displayed.
 - The monitor A, B and VCR outputs are switched to the selected display format set in the ALARM DISPLAY setup menu.
 - The unit exits the FREEZE mode, the VCR playback mode, or the VCR ZOOM mode.
 - All above actions are continued until the alarm is reset.
 - When any button is pressed during alarm stops the buzzer sound only before the alarm has released, and by pressing the followed second button the unit goes to the corresponding button display mode.
 - When multiple alarms occur, if the option is set FULL in Alarm Display Setup Menu, the outputs are switched between the alarmed cameras in numerical order automatically every two seconds.

The ALARM HOLD TIME can be set in the alarm time setup menu. It is started to count after the alarm has released.

The dwell time of the buzzer and the relay starts when an alarm is occurred and stops when the Alarm Hold Time is expired.

Note: When an alarm occurs, the FREEZE mode is canceled.

Note: The alarm is ignored for the camera with "DISABLE" option.

Alarm display

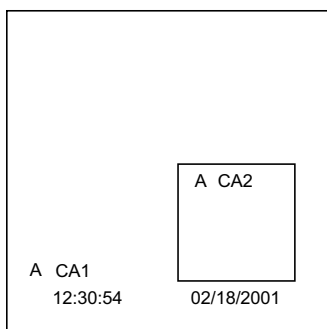

PIP1 DISPLAY MODE

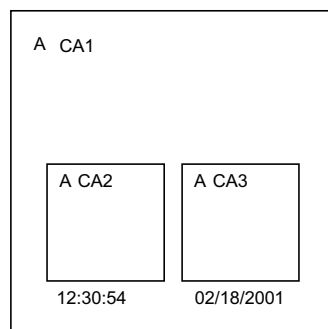

PIP2 DISPLAY MODE

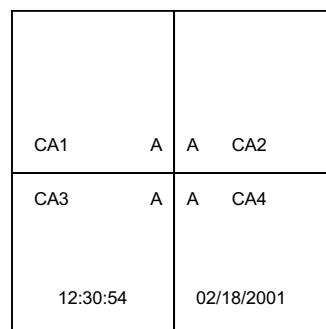

QUAD DISPLAY MODE

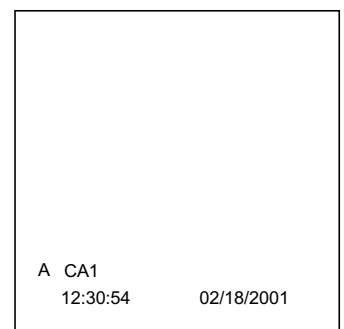

FULL DISPLAY MODE

VCR MODE When an alarm occurs in the VCR playback mode, it exits the VCR playback mode and performs the alarm operation. When the Alarm Hold Time has elapsed, it goes to the previous VCR mode.

ALARM

When an alarm occurs in VCR mode, the following actions occur:

1. The LED indicator of the alarmed camera blinks.
2. The alarm buzzer sounds, if enabled.
3. The alarm relay is energized, if enabled

VIDEO LOSS The color QUAD can detect the loss of video signal for all connected camera inputs.

ALARM

If the Video Loss Alarm has been set to OFF in the ALARM SETUP menu, then the loss of video signal is ignored. If the option is set to ON, the following actions occur:

- The Display mode is changed to the QUAD mode.
- The LEDs of the cameras with loss of video signal blink.
- The relays are energized if option is enabled.
- The alarm buzzer sounds if enabled.
- The “L” messages blink beside to the camera titles if the cameras with no video signal are displayed.
- The last picture of the camera with video loss is frozen in the QUAD mode.

The dwell time of video loss alarm is the same as the V-LOSS HOLD time in the alarm time setup menu. The V-LOSS HOLD time starts to count as soon as the unit detects no video signal.

The buzzer and the relay of Video loss start when the unit detects Video loss, and stop when the V-LOSS HOLD Time is expires. The video loss output goes out the logic level low during a video loss alarm. Pressing any button on video loss alarm stops the buzzer sound, turns off the relay and the LED of the camera with video loss. Then the unit goes to the corresponding button display mode by any followed button. But the blinking “L” message stops blinking and “L” message appears until the unit detects the new valid video signal on the camera with video loss.

Note: The video loss alarm is ignored in the camera with “DISABLE” option.

Note: When a video loss alarm of the camera not displayed on current screen occurs, the unit goes to QUAD display mode.

VCR MODE When a video loss alarm occurs in the VCR mode, the unit keeps the VCR playback mode.

VIDEO LOSS

ALARM

When an alarm occurs in VCR mode, the following actions occur:

1. The LED indicator of the alarmed camera blinks.
2. The alarm buzzer sounds, if enabled.
3. The alarm relay is energized, if enabled.

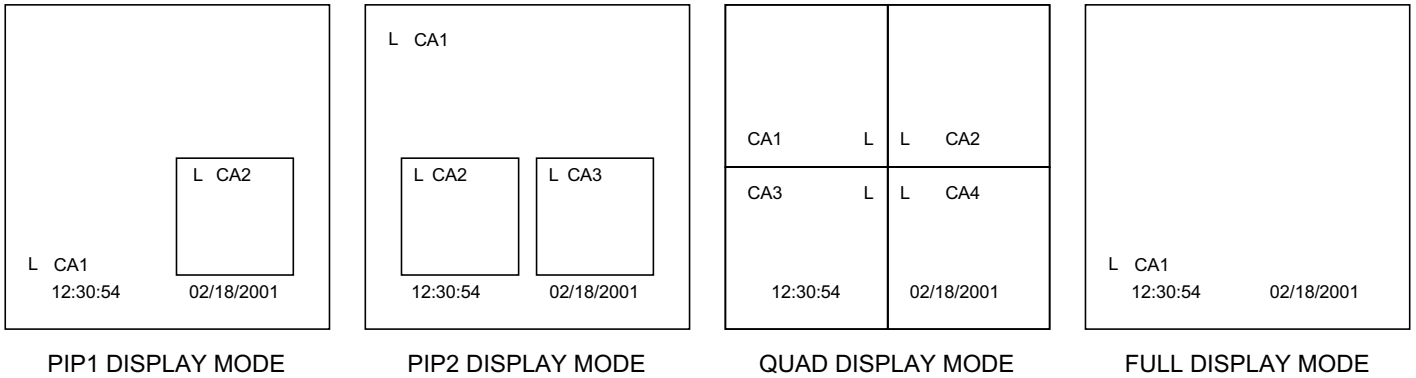

ALARM RESET When one of the following occurs, the alarm action finishes.

When the Alarm Hold Time has elapsed, that camera's alarm actions are terminated and the unit goes to previous mode.

When the V-LOSS HOLD time has elapsed, that camera's video loss alarm action is terminated.

Press any button to cancel an alarm action manually and the unit goes to the corresponding button display mode by pressing another button.

CONNECTORS Alarm Input:

The unit has eight alarm inputs, one alarm input is assigned to each camera input.

These inputs can be connected to any security device equipped with either a contact closure or TTL/CMOS standard alarm output. Alarm polarity can be selected for each input via the Alarm Input Setup menu.

Alarm input connections requires two wires. One wire connects to the desired alarm input pin.

The second wire connects to ground pin. If the alarm input for a camera has been turned OFF in the Alarm Input Setup menu, then the input is ignored.

Alarm output:

The unit has two alarm outputs that a Form "C" dry contact output. Normally open (N.O) and Normally closed (N.C) contacts with shared common.

Video loss output:

The unit has one Video-loss output. If the Video loss alarm occurs, the Video loss output is the Logic level low during video loss alarm.

CHAPTER 4. SETUP MODE

OVERVIEW

Pressing the MENU button places the unit into a programming mode.

Setup mode allows you to customize the unit operation to suit a specific application. In the setup mode, the arrow buttons are used as DOWN, UP, LEFT and RIGHT buttons. When the unit comes out from Setup menu, it comes to the previous display mode. In the menu mode, if any button is not pressed for two minutes, it will exit to operate in the previous mode.

Note: In this mode, alarms and video-loss alarm detection is disabled.

Password Option

PASSWORD PROTECTION

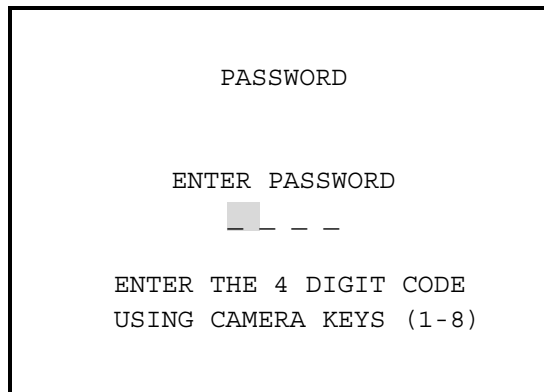

If the PASSWORD option is turned ON, pressing MENU displays the password confirmation screen. If the PASSWORD option is turned OFF, the password confirmation screen is bypassed and the MAIN MENU screen display. The four-digit password must be entered using the buttons for camera 1 through 8.

If the incorrect password is entered, the screen displays an access denied message two seconds and return to previous mode.

INCORRECT PASSWORD MESSAGE SCREEN

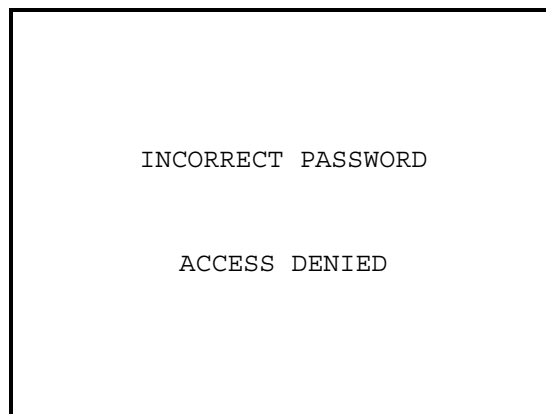

- Examples

If your password is "1 2 3 4", press the keys as CAM1, CAM2, CAM3, CAM4.

- Factory Default 1 1 1 1.

Main Menu Setup

OVERVIEW The main menu provides access to all programming facilities. The table below describes the functions of the programming and camera select controls.

Control	Description
MENU	From the main menu screen, exits the menu mode and return to the previous mode. Pressing this button while in a sub-menu returns to the upper menu screen.
SEL	Selects the setup option or enters the sub menu
△	Moves the cursor up or scrolls through the available options
▽	Moves the cursor down or scrolls through the available options
▷	Moves the cursor right
◁	Moves the cursor left
1 - 8	Enters a number from 1 to 8.

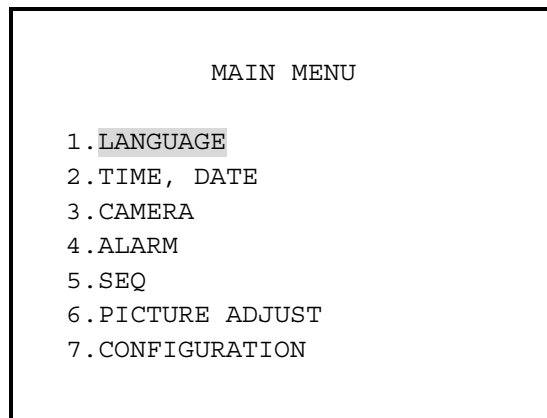

Language Setup

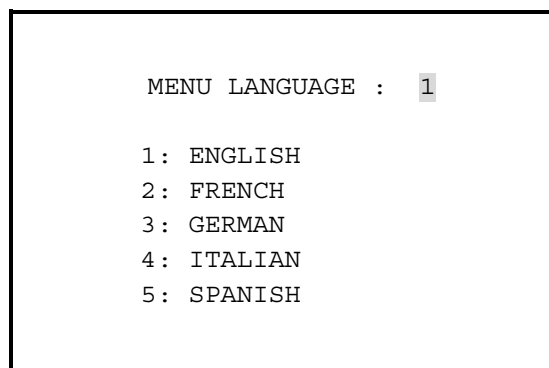

MENU LANGUAGE OPTION

The menu language option allows you to select the language on the displayed setup menu. The default setting is 1 (ENGLISH). Available languages are English, French, German, Italian and Spanish. Use the following steps to change this setting.

Step	Action
1	Press Δ or ∇ until you wanted menu language is selected.
2	Press MENU. The selected option is saved and the screen is moved to main menu.

Time And Date Setup

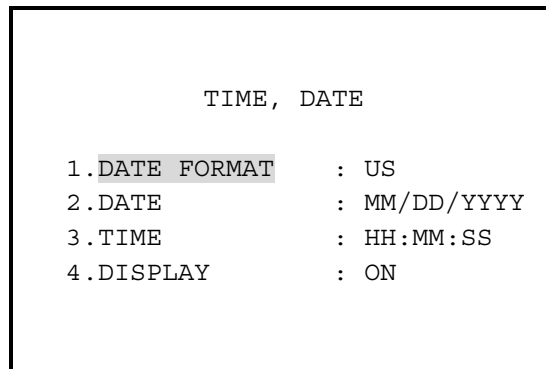

DATE FORMAT

The second option on the time and date setup screen is date format. This is used to select between the following three date formats:

FORMAT	DISPLAY	EXAMPLE
US (NTSC default)	MM/DD/YYYY	09/18/2000
EURO (PAL default)	DD/MM/YYYY	18/09/2000
ASIA	YYYY/MM/DD	2000/09/18

Use the following steps to set the date format option.

Step	Action
1	Press Δ or ∇ until Date Format is selected.
2	Press SEL to select the option.
3	Select the desired option using the Δ or ∇ buttons.
4	Press SEL. The selected option is saved and the cursor is moved to Date Format.

DATE

This field is used to set the current date. The format displayed on the screen is dependent on the data format option set in the preceding steps. Use the following steps to set the current date.

Step	Action
1	Press Δ or ∇ until Date is selected.
2	Press SEL to select the first two digits of the date.
3	Select the desired number using the Δ or ∇ button.

4	Select the next two digits using the ▷ or ◁ button.
5	Repeat steps three and four until the desired date is set.
6	Press SEL. The option is saved and the cursor is moved to Date.

TIME This field is used to set the time in a 24-hour format. Use the same steps above for setting the time.

DISPLAY OPTION The display option on the time and date setup screen allows you to select whether to display the time and date on the screen. The default option is ON. Change the display option using the steps in the following steps.

Step	Action
1	Press △ or ▽ until Display is selected.
2	Press SEL to select the option.
3	Select the desired option (ON or OFF) using the △ or ▽ button.
4	Press SEL. The selected option is saved and the cursor is moved to the Display option.

Camera Setup

OVERVIEW The camera setup screen allows you to change the camera titles, the camera disable/enable and PIP size option.

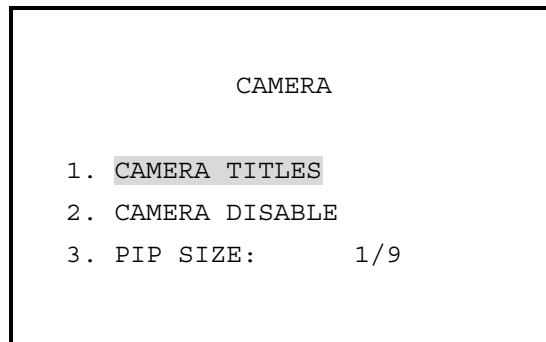

Camera Titles Setup

OVERVIEW The camera titles setup screen allows you to select whether or not to display titles for each camera when that camera is displayed, change the text displayed for each camera and move the position of the titles.

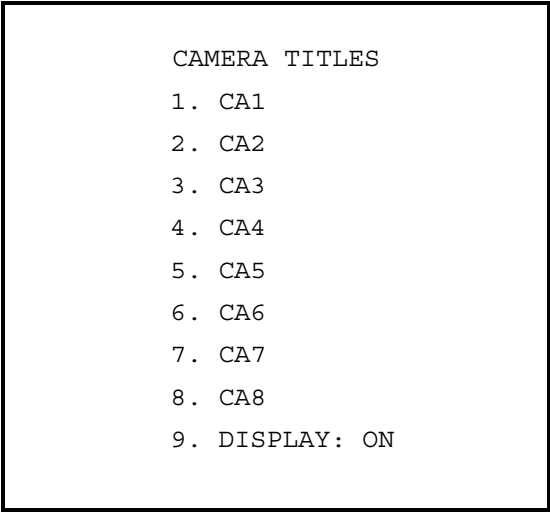

CAMERA TITLES

Numbers 1-8 on the camera titles setup screen are used to set each camera title. An 8-character title can be designated for each camera, and this title appears on the screen when the display option is ON and the camera is selected. The default camera title is “CA” with the corresponding number. Following are the available characters for camera titles regardless of the language setting:

A B C D E F G H I J K L M N O P Q R S T U V W X Y Z
a b c d e f g h i j k l m n o p q r s t u v w x y z
- . / 0 1 2 3 4 5 6 7 8 9 : = , ()
BLANK

The steps below provide an example for setting camera titles. In this example, set CA1 to “1:LOBBY.”

Step	Action
1	Press \triangle or ∇ until the number 1 is selected.
2	Press SEL to select the title.
3	Press \triangle or ∇ until the “1” character is displayed. Pressing \triangle scrolls one character at a time in ascending order. Pressing ∇ scrolls one character at a time in descending order. Holding down the \triangle or ∇ button for two seconds will scroll the characters automatically. Stop pressing \triangle or ∇ to stop scrolling.
4	Press \triangleright to move the cursor to the right. Press \triangle or ∇ until the “:” character is displayed.
5	Press \triangleright to move the cursor to the right. Press \triangle or ∇ until the “L” character is displayed.

6	Press \triangleright to move the cursor to the right. Press \triangle or ∇ until the "O" character is displayed.
7	Press \triangleright to move the cursor to the right. Press \triangle or ∇ until the "B" character is displayed.
8	Press \triangleright to move the cursor to the right. Press \triangle or ∇ until the "B" character is displayed.
9	Press \triangleright to move the cursor to the right. Press \triangle or ∇ until the "Y" character is displayed.
10	Press SEL. The title is saved and the cursor moves to 1.

**DISPLAY
OPTION**

The display option on the camera titles setup screen allows you to select whether or not to display camera titles on the screen. The default option is ON. Change the display option using the steps in the following steps.

Step	Action
1	Press \triangle or ∇ until Display is selected.
2	Press SEL to select the option.
3	Select the desired option (ON or OFF) using the \triangle or ∇ buttons.
4	Press SEL. The selected option is saved and the cursor is moved to Display.

Camera Disable Setup

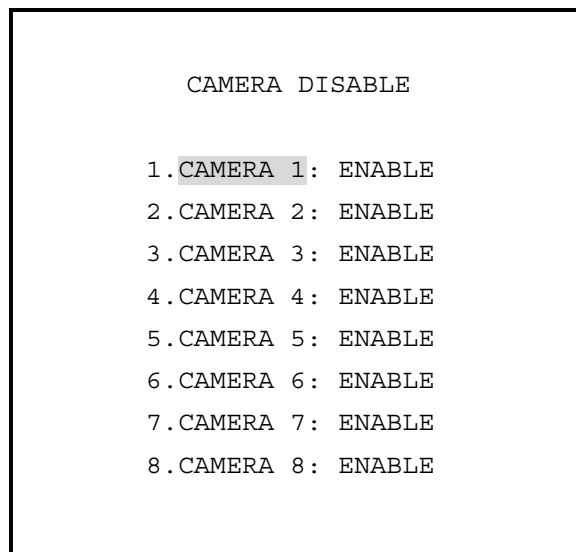

OVERVIEW

The camera disable setup screen allows you to disable a camera from the system even if it is physically connected to the system.

**CAMERA
DISABLE
SETUP**

When a camera is disabled, pressing the camera button for full screen viewing brings up a blue color screen with the title “DISABLED” if no camera is physically connected. It brings up a blue screen with no title if the camera is physically connected.

When a camera is disabled in quad mode, a black quadrant with the title “DISABLED” will be displayed if no camera is physically connected. It will display a black quadrant with no title if the camera is physically connected. When a camera is disabled, no action is taken on alarms.

The default option is ENABLE.

Step	Action
1	Press \triangle or ∇ until 1 is selected.
2	Press SEL to select the option.
3	Select the desired option (ENABLE or DISABLE) using the \triangle or ∇ button.
4	Press SEL. The selected option is saved and the cursor is moved to 1.
5	Repeat steps 1-4 until each desired item value is set.
6	To go to the CAMERA menu and press the MENU button.

a) When the camera has “DISABLE” option and the camera is physically connected.

	CA2
CA3	CA4
16:37:45	25/01/2000



b) When the camera has “DISABLE” option and no camera is physically connected.

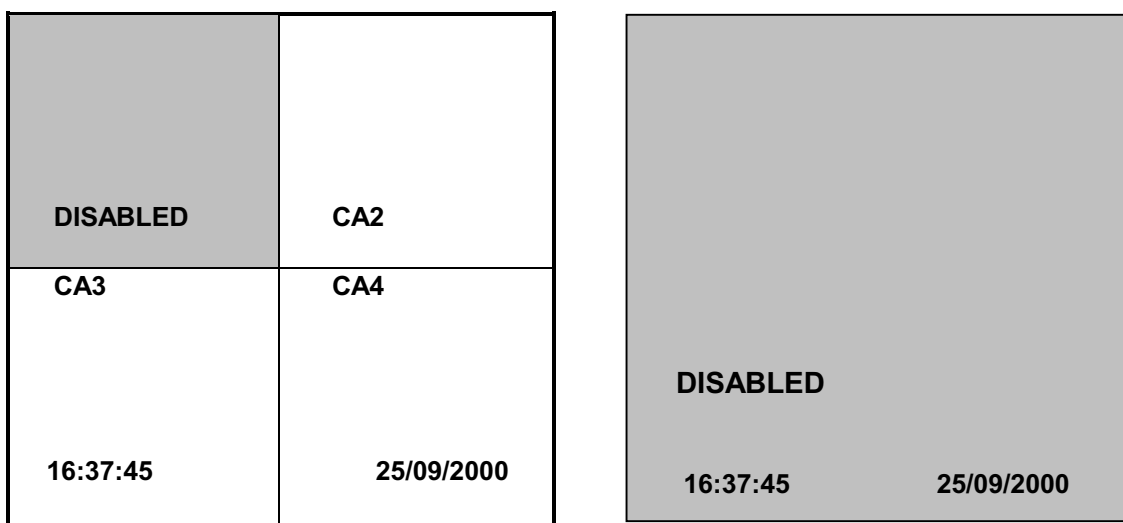

PIP Size Setup

PIP SIZE SETUP The PIP size setup allows you to select the inset picture size in the PIP1 or PIP2 mode. The default option is 1/9 size.

Step	Action
1	Press \triangle or ∇ until the PIP size option is selected.
2	Press SET to select the option.
3	Select the desired option (1/9 or 1/16 size) using the \triangle or ∇ button.
4	Press SET to save this option.

Alarm Setup

OVERVIEW The alarm setup screen allows you to select the alarm input, the video loss alarm on/off, the display on alarm and alarm time.

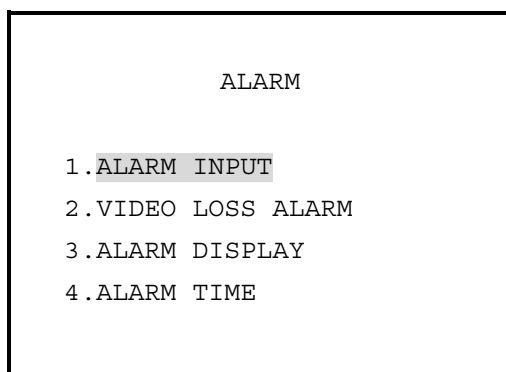

Alarm Input Setup

Alarm inputs define the way connectors respond to external input, in terms of whether they are normally open (NO), normally closed (NC), or if they ignore the input. The default is normally open (NO). The alarm input setup screen allows you to set these options.

Note: Any alarm that occurs while in the setup mode is ignored.

ALARM INPUT	
1.	ALARM 1 : N.O
2.	ALARM 2 : N.O
3.	ALARM 3 : N.O
4.	ALARM 4 : N.O
5.	ALARM 5 : N.O
6.	ALARM 6 : N.O
7.	ALARM 7 : N.O
8.	ALARM 8 : N.O
9.	LATCH : OFF
10.	BUZZER : ON
11.	RELAY : ON

INPUT OPTIONS

The alarm numbers displayed on the screen allow you to change the alarm input options. Use the following steps to change the option for each camera.

Step	Action
1	Press \triangle or ∇ to move the cursor to the desired number.
2	Press SEL to select the current option.
3	Select the new option using the \triangle or ∇ buttons. Valid settings are: <ul style="list-style-type: none">• OFF: The alarm input is ignored.• N.O: The unit looks for a short for alarm condition.• N.C: The unit looks for an open for alarm condition.
4	Press SEL to save the change.
5	Repeat steps 1 through 4 for all other desired cameras.

LATCH

This option is used to determine how long the alarm message will display in the main monitor.

Step	Action
1	Press \triangle or ∇ to move the cursor to the Alarm Latch option.
2	Press SEL to select the current option.
3	Press \triangle or ∇ to change the value. Select from the following: <ul style="list-style-type: none"> • ON: All alarm messages remain on screen and the LED indicators of alarmed cameras will blink until manually cleared by entering the setup menu. • OFF: Each alarm message remains on screen until the alarm hold time expires or manually cleared by pressing any button. This is the default setting.
4	Press SEL to save the new option and return the cursor to Alarm Latch.

BUZZER

The alarm buzzer option allows you to select whether the alarm buzzer is turned on or off. Use the following steps to change this option.

Step	Action
1	Press \triangle or ∇ to move the cursor to the Alarm Buzzer option.
2	Press SEL to select the current option.
3	Press \triangle or ∇ to change the option. Select from the following: <ul style="list-style-type: none"> • ON: activates the alarm buzzer until the alarm hold time expires or manually cleared by pressing any button. This is the default setting. • OFF: turns the alarm buzzer off.
4	Press SEL to save the new option and return the cursor to Alarm Buzzer.

RELAY

The alarm relay option allows you to select whether the alarm relay is turned on or off. Use the following steps to change this option.

Step	Action
1	Press \triangle or ∇ to move the cursor to the Alarm relay option.
2	Press SEL to select the current option.
3	Press \triangle or ∇ to change the option. Select from the following: <ul style="list-style-type: none"> • ON: activates the alarm relay until the alarm hold time expires or manually cleared by pressing any button. This is the default setting. • OFF: turns the alarm relay off.
4	Press SEL to save the new option and return the cursor to Alarm Relay.

Video Loss Alarm

The video loss alarm allows you to turn the video loss alarm on or off for each camera when video input is lost. Use the following steps to change this option.

Step	Action
1	Press \triangle or ∇ to move the cursor to the Video Loss Alarm option.
2	Press SEL to select the current option.
3	Press \triangle or ∇ to change the value. Select from the following: <ul style="list-style-type: none">• ON: Executes video loss alarm operation during loss of video. This is the default setting.• OFF: Ignores the loss of video.
4	Press SEL to save the change.
5	Repeat steps 1 through 4 for all other desired cameras.

VIDEO LOSS ALARM

```
1 . CAMERA 1 : ON
2 . CAMERA 2 : ON
3 . CAMERA 3 : ON
4 . CAMERA 4 : ON
5 . CAMERA 5 : ON
6 . CAMERA 6 : ON
7 . CAMERA 7 : ON
8 . CAMERA 8 : ON
9 . LATCH   : OFF
10 . BUZZER : ON
11 . RELAY  : ON
```

LATCH

This option is used to determine how long the video loss alarm message will display in the monitor.

Step	Action
1	Press \triangle or ∇ to move the cursor to the Video Loss Latch option.
2	Press SEL to select the current option.
3	Press \triangle or ∇ to change the value. Select from the following: <ul style="list-style-type: none"> • ON: All video loss alarm messages remain on the screen and the LED indicators of cameras without video signal will blink until manually cleared by entering the setup menu. • OFF: Each video loss message remains on screen until the V-LOSS time expires or manually cleared by entering the setup menu. This is the default setting.
4	Press SEL to save the new option and return the cursor to Video Loss Latch.

BUZZER

The video loss buzzer allows you to enable or disable the buzzer when the video loss alarm is set to ON. The buzzer sounds until the V-LOSS time expires, if enabled. Use the following steps to change this option.

Step	Action
1	Press \triangle or ∇ to move the cursor to the Video Loss Buzzer option.
2	Press SEL to select the current option.
3	Press \triangle or ∇ to change the value. Select from the following: <ul style="list-style-type: none"> • ON: Sounds the buzzer until the V-LOSS time expires or manually cleared by pressing any button This is the default setting. • OFF: Does not sound the buzzer.
4	Press SEL to save the new option and return the cursor to Buzzer.

RELAY

The Video Loss relay option allows you to select whether the relay is turned on or off. Use the following steps to change this option.

Step	Action
1	Press \triangle or ∇ to move the cursor to the Video Loss relay option.
2	Press SEL to select the current option.
3	Press \triangle or ∇ to change the option. Select from the following: <ul style="list-style-type: none"> • ON: activates the relay until the V-LOSS time expires or manually cleared by pressing any button. This is the default setting. • OFF: turns the relay off.
4	Press SEL to save the new option and return the cursor to Relay.

Alarm Display Setup

ALARM DISPLAY SETUP The alarm display option allows you to select the display format regardless of the video-loss alarm when the external alarm occurs. The default alarm display is 1. Change this option using the following steps.

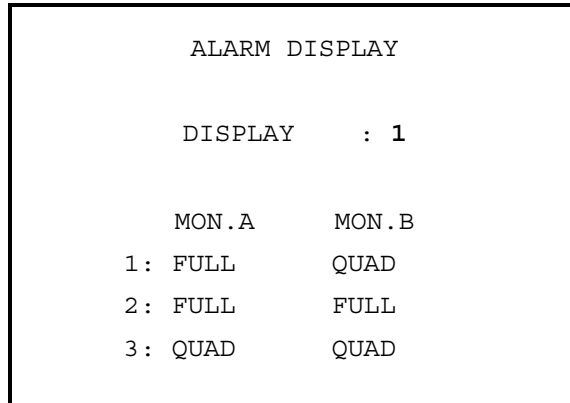

Step	Action
1	Press SEL to select the current option.
2	Press Δ or ∇ to move the cursor to the desired number.
3	Press SEL to save the change.
4	Press the MENU button to go to upper menu.

Alarm Time Setup

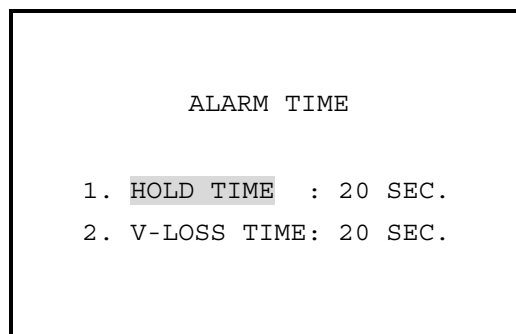

HOLD TIME OPTION This option is used to set the amount of time that the alarm relay and alarm display continues after the alarm has released. Change this option using the following steps.

Step	Action
1	Press Δ or ∇ to move the cursor to the Hold Time option.
2	Press SEL to select the current option.
3	Press Δ or ∇ to change the number of seconds. Valid settings are from 0 to 99 seconds. The default setting is 20 seconds.
4	Press SEL to save the new option and return the cursor to Hold Time.

V-LOSS TIME OPTION This option is used to set the amount of time that the video loss alarm relay, buzzer and display continues after the unit detects the new video signal of the camera with video loss. Change this option using the following steps.

Step	Action
1	Press Δ or ∇ to move the cursor to the Video Loss Time option.
2	Press SEL to select the current option.
3	Press Δ or ∇ to change the number of seconds. Valid settings are from 1 to 99 seconds. The default setting is 20 seconds.
4	Press SEL to save the new option and return the cursor to V-LOSS Time.

Sequence Setup

OVERVIEW The sequence setup menu allows you to select whether or not to display cameras in the sequential switching modes, and if so, specify the number of seconds each camera displays. The order and dwell time in the full sequence option applies to the PIP sequence display mode.

SEQUENCE		
* QUAD DWELL TIME: 03 SEC.		
* FULL SEQUENCE:		
	ORDER	DWELL
1:	CA1	03 SEC.
2:	CA2	03 SEC.
3:	CA3	03 SEC.
4:	CA4	03 SEC.
5:	QUADA	OFF
6:	CA5	00 SEC.
7:	CA6	00 SEC.
8:	CA7	00 SEC.
9:	CA8	00 SEC.
10:	QUADB	OFF

QUAD DWELL TIME OPTION The QUAD Dwell Time option is used for the page sequence mode in the QUAD display mode. Valid dwell times are from 00 to 99 seconds. If 00 second is selected, the word OFF is displayed on the screen. The 00 second means the QUAD display will not sequence. Three seconds is the default dwell time but the QUAD is OFF. Use the following steps to set the dwell time for the QUAD Dwell Time option.

Step	Action
1	Press Δ or ∇ to move the cursor to the QUAD dwell time option.
2	Press SEL to select the dwell time.
3	Press Δ or ∇ to set the dwell time.
4	Press SEL to save the new dwell time.

ORDER OPTION The order option allows you to select the switching order in the sequential switching modes. A camera is able to be set more than once in the sequence order. Change this option using the following steps.

Step	Action
1	Press Δ or ∇ to move the cursor to the desired number.
2	Press SEL to select the current option.
3	Select the new option using the Δ or ∇ button.
4	Press SEL to save the change.
5	Repeat steps 1 through 4 for all other desired numbers.

DWELL TIME OPTION The dwell time option is used for the sequential switching mode for each camera. Valid dwell times are from 00 to 99 seconds. If 00 second is selected, the word OFF is displayed on the screen. Three seconds is the default dwell time. Use the following steps to set the dwell time for each camera.

Step	Action
1	Press Δ or ∇ to move the cursor to the desired number.
2	Press SEL to select the current option.
3	Press \triangleright or \triangleleft to move the cursor to the dwell time.
4	Press Δ or ∇ to set the dwell time.
5	Press SEL to save the new dwell time.
6	Repeat steps 1 through 5 to set other dwell times.

SKIP FEATURES Cameras that have a dwell time set to OFF will be excluded from the switching sequence even if they are connected to the system. Cameras with dwell times from 01-99 seconds will be displayed.

Picture Adjust

OVERVIEW The Picture Adjust menu allows you to modify the picture quality of the selected camera.

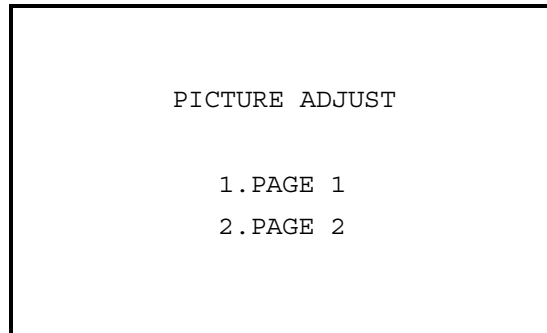

CAMERA SELECT Select the camera for adjust picture quality using the following steps.

Step	Action
1	Press \triangle or ∇ to move the cursor to the desired page.
2	Press SEL to change the picture quality. Then the screen goes to the control menu. Or press the MENU button to go to upper menu

OSD when Adjust quadrant 1

CA1	
1 . QUADRANT	: 1
2 . BRIGHTNESS	: -01
3 . CONTRAST	: MIN
4 . COLOR	: MAX
5 . TINT	: +03

OSD when Adjust Camera 7

1 . QUADRANT	: 7
2 . BRIGHTNESS	: 00
3 . CONTRAST	: 00
4 . COLOR	: 00
5 . TINT	: 00
CA7	

PICTURE ADJUST This menu allows you to adjust the level for brightness, contrast, color and tint of the selected camera. These levels are controlled by 64 steps from MIN to MAX. The 00 means the normal value. The default setting is 00. Change the value for picture control using the following steps.

Step	Action
1	Press \triangle or ∇ to move the cursor to the desired item.
2	Press SEL to change the value.
3	Press \triangle or ∇ to change the value.
4	Press SEL. The selected option is saved and the cursor is moved to the item.
5	Repeat steps 1 through 4 for all other desired item.
6	Press the MENU button to go to Upper menu

Note: THE TINT IS ONLY NTSC MODEL.

Configuration

OVERVIEW The configuration setup screen allows you to make changes to the security options. On this screen, you can setup password confirmation, security codes, factory defaults, protection against unauthorized operation, VCR input, remote control.

CONFIGURATION	
1 .	PASSWORD : OFF
2 .	ENTER NEW CODE : _ _ _ _
	RE-ENTER NEW CODE: _ _ _ _
3 .	FACTORY DEFAULT : NO
4 .	KEY LOCK : OFF
5 .	VCR INPUT : BNC
6 .	REMOTE CONTROL
7 .	ALARM HISTORY
8 .	SYSTEM : NTSC

PASSWORD The password option is used to protect programming setup from unauthorized access. If this option is ON, pressing MENU to enter the main menu setup mode will display the password confirmation screen.

Step	Action
1	Press \triangle or ∇ until Password is selected.
2	Press SEL to select the option.
3	Select the desired option (ON or OFF) using the \triangle or ∇ button.
4	Press SEL to save the setting and move the cursor to the Password option.

CHANGING THE PASSWORD The Enter New Code and Re-enter New Code fields are used to change the password for the unit. Use the following steps to change the password.

Step	Action
1	Press \triangle or ∇ until Enter New Code is selected.
2	Press SEL to select the first digit of the password.
3	Enter four digits for the new password using the quadrant number buttons 1 through 8.
4	The first digit (-) of the Re-enter new password field is automatically selected.
5	Re-enter the same four digits as above and press SEL.
6	If the changing password code was successful, an "change password success" message screen is displayed at two seconds and the cursor place the ENTER NEW CODE menu-item automatically. If not, a "change password fail" message screen is displayed at two seconds and the cursor place the ENTER NEW CODE menu-item automatically. In this case, repeat the same steps.

CHANGE PASSWORD

SUCCESS

CHANGE PASSWORD

FAIL

FACTORY DEFAULTS

This option allows you to return to the unit to all factory-defined defaults.

The default setting is NO. Use the following steps to reset the unit to factory defaults.

Warning: This action erases all user settings and cannot be undone.

Step	Action
1	Press \triangle or ∇ until Factory Defaults is selected.
2	Press SEL to select the option. A warning message is displayed in the message portion of the screen : <div style="border: 1px dashed black; padding: 10px; text-align: center;"> <p>----- Warning ----- This will change all user settings to the factory default.</p> </div>
3	Select the desired option (YES) using the \triangle or ∇ button.
4	Press MENU to cancel this action. Or press SEL to save the setting. Then "Factory Default is Done" is displayed on the screen.

WARNING

THIS WILL CHANGE
ALL USER SETTINGS TO
THE FACTORY DEFAULT.

FACTORY DEFAULT
IS DONE.

KEY LOCK

This option is used to protect the control buttons against unauthorized operation. Use the following steps to set the key lock option.

Step	Action
1	Press \triangle or ∇ until Key Lock is selected.
2	Press SEL to select the option.
3	Press \triangle or ∇ to select the new option. Valid settings are: <ul style="list-style-type: none">• ON: The front panel is inoperable. Pressing MENU will place the unit into the main menu setup mode.• OFF: The front panel is operable and key lock is off. This setting is default.
4	Press SEL to save the setting and move the cursor to the Key Lock option.

VCR INPUT OPTION

The VCR Input option allows you to change the VCR input format. Use the following steps to change the option.

Step	Action
1	Press \triangle or ∇ to move the cursor to the VCR Input option.
2	Press SEL to select the current option.
3	Select the new option using the \triangle or ∇ buttons. Valid settings are: <ul style="list-style-type: none">• BNC: The VCR video signal come from the BNC jack.• SVHS: The VCR video signal come from the SVHS mini-DIN jack.
4	Press SEL to save the change.

REMOTE CONTROL

This Remote Control setup menu allows you to set the UNIT number and Data rate.

REMOTE CONTROL
1. UNIT NUMBER: 01
2. TYPE: RS485
3. DATA RATE: 1200BPS

UNIT NUMBER This option is used to assign the unit number. Use the following steps to set the unit number.

Step	Action
1	Press Δ or ∇ until Unit Number is selected.
2	Press SEL to select the option.
3	Press Δ or ∇ to select the desired number, from 01 to 99. The default setting is 01.
4	Press SEL to save the changes and return to the Unit Number option.

TYPE This option is used to assign the type of the communication. Use the following steps to set the type.

Step	Action
1	Press Δ or ∇ until the type option is selected.
2	Press SEL to select the option.
3	Select the desired option (RS-232 or RS-485) using the Δ or ∇ button. The RS-485 is default setting.
4	Press SEL to save the changes and return to the TYPE option.

DATA RATE This option is used to assign the data rate for remote control. Available settings are 1200BPS, 2400BPS, 4800BPS and 9600BPS. Use the following steps to set the unit number.

Step	Action
1	Press Δ or ∇ until data rate is selected.
2	Press SEL to select the option.
3	Press Δ or ∇ to select the desired number, 1200BPS, 2400BPS, 4800BPS and 9600BPS. The default setting is 1200BPS.
4	Press SEL to save the changes and return to the Data Rate option.

ALARM HISTORY The alarm history option is used to display the history for up to 120 alarm events. The history data including alarm source, camera number, time and date is displayed in 10 different pages. The alarm history is kept in a cyclic. So the last sixteen alarm events are recorded with the oldest alarm event being deleted when triggered again.

There are three different sources:

“A” means that the alarm was triggered by the external alarm sensor.

“L” means that the alarm was triggered by the loss of the video signal from the camera input.

Use the following steps to display the alarm history for each alarm and restart the alarm history for all cameras.

Step	Action
1	Press \triangle or ∇ until Alarm History is selected.
2	Press SEL to display the current alarm history.
3	Press UP to display the next page or press the SEL to clear all pages.
4	Press the MENU button to exit this menu and to the configuration menu.

ALARM HISTORY		PAGE1
A CA1	12:05:36	10/30/2000
L CA3	13:05:36	10/29/2000
L CA8	14:05:36	10/28/2000
A CA2	15:05:36	10/27/2000
A CA3	16:05:36	10/26/2000
L CA4	17:05:36	10/25/2000
A CA5	18:05:36	10/24/2000
A CA8	19:05:36	10/23/2000
A CA7	20:05:36	10/22/2000
A CA1	21:05:36	10/23/2000
A CA3	21:22:31	10/22/2000
A CA6	22:07:07	10/21/2000
PRESS SEL TO CLEAR		

ALARM HISTORY		PAGE1
/ NO ALARM /		
PRESS SEL TO CLEAR		

SYSTEM

This option is used to assign the system format of the video signal. Use the following steps to set the type.

Note: This option is not changed by the factory default operation.

Note: At the power on, after this unit check the system format of the camera 1, it operates as follows:

1. If the system format of the camera 1 is not same as this option value, it changes this option value to the system format of the camera 1.
2. If the camera 1 is not installed, this unit displays with the system format of this option value.

Step	Action
1	Press \wedge or \vee until the system option is selected.
2	Press SEL to select the option.
3	Select the desired option (NTSC or PAL) using the \triangle or ∇ button.
4	Press SEL to save.

CHAPTER 5. REMOTE CONTROL

Overview

OVERVIEW	The unit provides three methods of remote control using the rear panel REMOTE connector: RS-232 data, RS-485 data.
RS-232 AND RS-485 DATA	<p>The RS-232 and RS-485 data remote features allow the unit to be controlled from a computer or ASCII communications terminal. The unit recognizes three character groups as a remote button press command. Each command represents a single button press.</p> <p>The RS-232 remote pin is an input only. The RS-485 pin (RXA, RXB) is used only to receive data. The unit does not echo commands or output data of any type.</p> <p>Warning: Only one serial communication method should be used between RS-232 and RS-485.</p>
RS-232 CONNECTION	RS-232 remote connection requires two wires. One wire connects to the RS-232 pin (PIN 2) and the other connects to the ground pin (PIN 5).
RS-485 CONNECTION	<p>RS-485 remote control is through a RJ-45 connector on the rear panel.</p> <p>RS-485 remote connection requires two wires. One wire connects to the RS-485 RXA and the other connects to the RS-485 RXB. And the RXS and RXB should be connected externally. But if user connects more than two units, the user should have only one unit that RXS and RXB are connected externally.</p> <p>Note: Twist the wires together to help eliminate noise from the signal.</p>
COMMUNICATION PROTOCOL	<p>The communication protocol supported by this unit is as follows:</p> <ul style="list-style-type: none">• Data rate: 1200bps, 2400bps, 4800bps, 9600bps (Selectable)• Characters: 8• Parity: None• Stop bits: 1
REMOTE COMMAND SET	The following remote commands consist of three ASCII characters. All commands, except unit number commands, begin with the forward slash (/) character. The two characters following the slash identify the command. The following table lists each valid command and the button press it represents.

Remote Command Set

FUNCTION	COMMAND
MENU button	/MU
SEL button	/SL
VCR button	/VR
QUAD button	/QU
SEQUENCE button	/SQ
FREEZE button	/FR
PIP1 button	/P1
PIP2 button	/P2
CAMERA 1~8 button	/01~/08
QUAD1 mode	/Q1
QUAD2 mode	/Q2
UP button	/UP
DOWN button	/DN
LEFT button	/LT
RIGHT button	/RT
Freeze Mode	/FM
Unfreeze Mode	/UM
Unit Number	#00 ~#99

The unit operates according to all command after power on. If the unit receives the command, Unit Number, the unit compares the received unit number command with it self in the menu setup.

On receiving the wrong unit number, the unit does not operate by command until receiving U00 or same number as itself.

Remote Connection

RS-232 connection

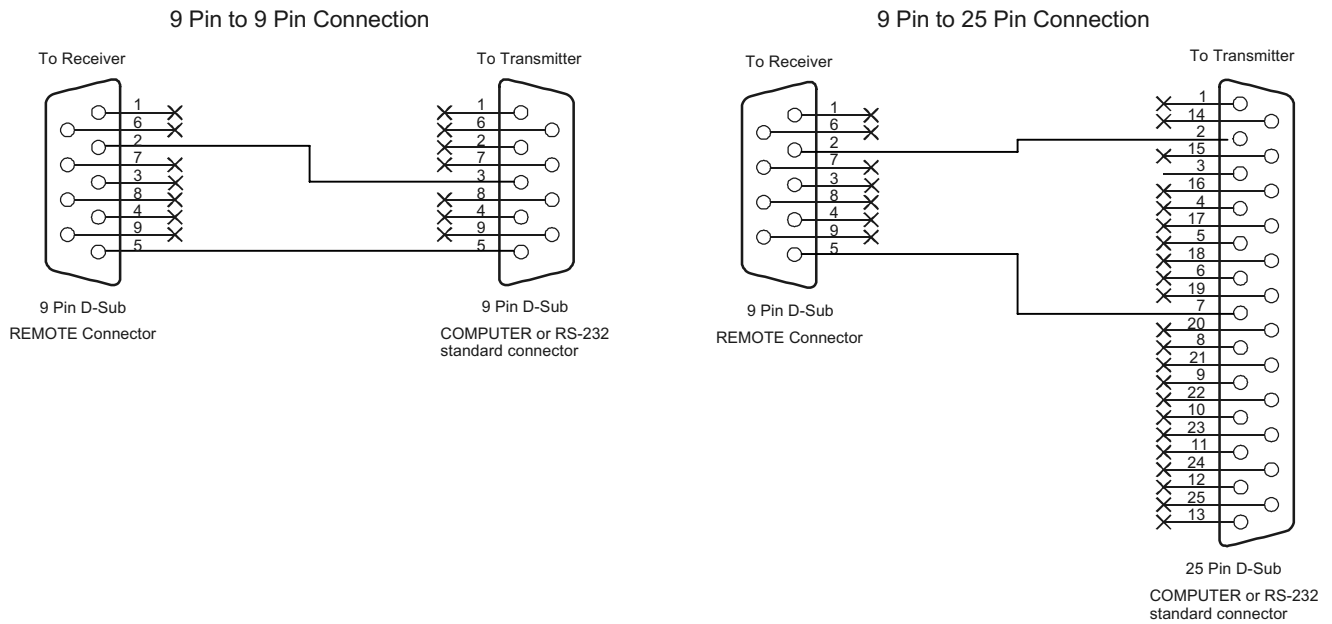

RS-232 transmitting connector pin name

RS-232 Pin Name	Pin No. (25 Pin D-Sub Connector)	Pin No. (9 Pin D-Sub Connector)
TXD	3	3
RXD	2	2
RTS	4	7
CTS	5	8
DSR	6	6
GND	7	5
DCD	8	1
DTR	20	4

RS-485

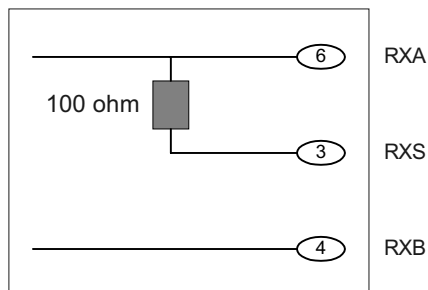

CHAPTER 6. TECHNICAL SPECIFICATIONS

Power ON	Display Format	Quad Screen Display (Page 1)
Factory Defaults	Menu Language	ENGLISH
	Time/date Display	ON
	Date format	NTSC: US (MM/DD/YY), PAL: EURO (DD/MM/YY)
	Camera Titles	ON (CA1 ~ 8)
	Camera Disable	All Enable
	Quadrant Assign	Page 1 (Q1: CA1, Q2: CA2, Q3: CA3, Q4: CA4) Page 2 (Q1: CA5, Q2: CA6, Q3: CA7, Q4: CA8)
	Alarm Input Polarity	N.O (Normally Open)
	Alarm Display	1 (MON.A : FULL, MON.B/VCR : QUAD)
	Alarm Buzzer	ON
	Alarm Hold Time	20 seconds
	Alarm Latch	OFF
	Alarm Relay	ON
	Video Loss Alarm	ON
	Video Loss Latch	OFF
	Video Loss Time	20 seconds
	Video Loss Relay	ON
	Sequence Order	CA1, CA2, CA3, CA4, CA5, CA6, CA7, CA8
	Dwell Time	3 seconds (Except QUAD : OFF)
	Password	OFF
	Password Code	1 1 1 1
	Key Lock	OFF
	Factory Default	NO
	VCR Input	BNC
	Data Rate	1200bps
	Unit Number	01
Alarm	Camera Alarm Input	Eight inputs with individual polarity selection. Activated by contact closure or TTL/CMOS signal.
	Alarm Output	Two N.O and N.C contacts with shared common. 1.0A at 24 VDC (resistive only)
	Alarm Hold Time	20 seconds (default) Programmable 00 to 99 seconds.
	Alarm Buzzer	On/Off programmable.
	Relay	On/Off programmable.
Operating Environment	Ambient Temp.	32°F to 95F (0°C to 35°C)
	Ambient Humidity	10% to 90% (non-condensing)

Continued on the next page

Electrical	Signal Format	NTSC: 525 lines / PAL: 625 lines, 2:1 Interlace
	Video Inputs	1.0 Vp-p 75 Ohm, BNC(×8)
	Video Outputs	BNC with switch for changing input impedance automatically. Composite video output from camera (passive loop through).
	VCR Output	1.0 Vp-p, 75 Ohm NTSC, BNC and, 1.0Vp-p, S-Luma (Y), 75 Ohm, S-Video, 4 Pin Mini-Din and, 0.286Vp-p S-Chroma (C), S-Video, 4 Pin Mini-Din, OSD
	VCR Input	1.0 Vp-p, 75 Ohm NTSC, BNC or 1.0Vp-p, S-Luma (Y), 75 Ohm, S-Video, 4 Pin Mini-Din and 0.286Vp-p S-Chroma (C), S-Video, 4 Pin Mini-Din
	MON.A Output	1.0 Vp-p, 75 ohm unbalanced, BNC, OSD
	MON.B Output	1.0 Vp-p, 75 ohm unbalanced, BNC, OSD
	Pixel Resolution	720 x 480 pixels (NTSC) / 720 x 576 pixels (PAL)
	Shades of Gray	256
	Colors	16.7 Million
	Display Rate	Real Time Refresh Rate (60/50 Field Per Second per Quadrant)
	Video Dwell	OFF, 01 to 99 seconds programmable
	Alarm Inputs	Normally Open or Normally Closed (Programmable), Terminal Strip
	Alarm Outputs	Form C Dry Contact, Terminal Strip (x2)
	Video Loss Alarm	OSD Display ("L"), BUZZER, and Relay
	Freeze Annunciation	OSD Display ("F")
	Annunciation	Alarm Buzzer (On/Off)
Camera Titles	Eight characters per Camera	
<hr/>		
Power Requirement	12V DC / 1.5A	
<hr/>		
Physical Characteristics	Dimensions (W x H x D)	17.5" x 1.73" x 13.1" (444.5mm x 44mm x 334mm)
	Weight	2.3 Kg
<hr/>		