

# INSTRUCTION MANUAL

## BLACK & WHITE CAMERA

---

1/3" INTERLINE TRANSFER CCD  
STANDARD RESOLUTION  
HIGH RESOLUTION

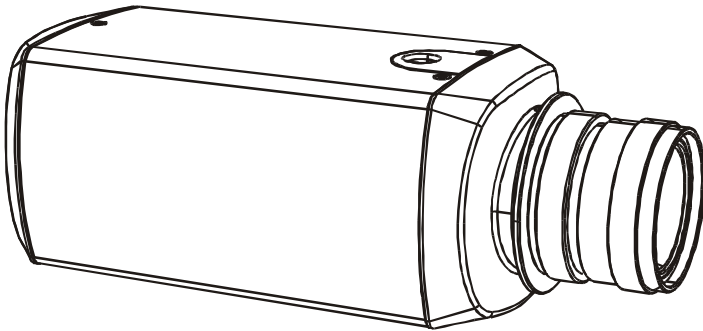

*Please read this manual thoroughly before use, and keep it handy for future reference.*

**ISSUE 2 – MAY 2001**

## WARNINGS AND CAUTIONS

TO REDUCE THE RISK OF FIRE OR ELECTRIC SHOCK, DO NOT EXPOSE THIS PRODUCT TO RAIN OR MOISTURE. DO NOT INSERT ANY METALLIC OBJECTS THROUGH THE VENTILATION GRILLS OR OTHER OPENINGS ON THE EQUIPMENT.

### CAUTION



### EXPLANATION OF GRAPHICAL SYMBOLS



The lightning flash with arrowhead symbol, within an equilateral triangle, is intended to alert the user to the presence of uninsulated “dangerous voltage” within the product’s enclosure that may be of sufficient magnitude to constitute a risk of electric shock to persons.



The exclamation point within an equilateral triangle is intended to alert the user to the presence of important operating and maintenance (servicing) instruction in the literature accompanying the product.

## FCC COMPLIANCE STATEMENT

**INFORMATION TO THE USER:** THIS EQUIPMENT HAS BEEN TESTED AND FOUND TO COMPLY WITH THE LIMITS FOR A CLASS B DIGITAL DEVICE, PURSUANT TO PART 15 OF THE FCC RULES. THESE LIMITS ARE DESIGNED TO PROVIDE REASONABLE PROTECTION AGAINST HARMFUL INTERFERENCE IN A RESIDENTIAL INSTALLATION. THIS EQUIPMENT GENERATES, USES AND CAN RADIATE RADIO FREQUENCY ENERGY AND, IF NOT INSTALLED AND USED IN ACCORDANCE WITH THE INSTRUCTIONS, MAY CAUSE HARMFUL INTERFERENCE TO RADIO COMMUNICATIONS. HOWEVER, THERE IS NO GUARANTEE THAT INTERFERENCE WILL NOT OCCUR IN A PARTICULAR INSTALLATION. IF THIS EQUIPMENT DOES CAUSE HARMFUL INTERFERENCE TO RADIO OR TELEVISION RECEPTION, WHICH CAN BE DETERMINED BY TURNING THE EQUIPMENT OFF AND ON, THE USER IS ENCOURAGED TO TRY TO CORRECT THE INTERFERENCE BY ONE OR MORE OF THE FOLLOWING MEASURES:

- REORIENT OR RELOCATE THE RECEIVING ANTENNA
- INCREASE THE SEPARATION BETWEEN THE EQUIPMENT AND RECEIVER
- CONNECT THE EQUIPMENT INTO AN OUTLET ON A CIRCUIT DIFFERENT FROM THAT TO WHICH THE RECEIVER IS CONNECTED
- CONSULT THE DEALER OR AN EXPERIENCED RADIO/TV TECHNICIAN FOR HELP

**CAUTION:** CHANGES OR MODIFICATIONS NOT EXPRESSLY APPROVED BY THE MANUFACTURER COULD VOID THE USER'S AUTHORITY TO OPERATE THE EQUIPMENT.

THIS CLASS B DIGITAL APPARATUS COMPLIES WITH CANADIAN ICES-003.

CET APPAREIL NUMÉRIQUE DE LA CLASSE B EST CONFORME À LA NORME NMB-003 DU CANADA.

# IMPORTANT SAFEGUARDS

---

## 1. **READ AND RETAIN INSTRUCTIONS**

Read the instruction manual before operating the equipment. Retain the manual for future reference.

## 2. **CLEANING**

Turn the unit off and unplug from the power outlet before cleaning. Use a damp cloth for cleaning. Do not use harsh cleansers or aerosol cleaners.

## 3. **ATTACHMENTS**

Do not use attachments unless recommended by manufacturer as they may affect the functionality of the unit and result in the risk of fire, electric shock or injury.

## 4. **MOISTURE**

Do not use equipment near water or other liquids.

## 5. **ACCESSORIES**

Equipment should be installed in a safe, stable location. Any wall or shelf mounting accessory equipment should be installed using the manufacturer's instructions. Care should be used when moving heavy equipment. Quick stops, excessive force, and uneven surfaces may cause the equipment to fall causing serious injury to persons and objects.

## 6. **VENTILATION**

Openings in the equipment, if any, are provided for ventilation to ensure reliable operation of the unit and to protect it from overheating. These openings must not be blocked or covered

## 7. **POWER SOURCES**

The equipment should be operated only from the type of power source indicated on the marking label. If you are not sure of the type of power supplied at the installation location, contact your dealer. For equipment designed to operate from battery power, refer to the operating instructions.

## 8. **GROUNDING OR POLARIZATION**

Equipment that is powered through a polarized plug (a plug with one blade wider than the other) will fit into the power outlet only one way. This is a safety feature. If you are unable to insert the plug fully into the outlet, try reversing the plug. Do not defeat the safety purpose of the polarized plug.

Alternate Warning: If the equipment is powered through a three-way grounding-type plug, a plug having a third (grounding) pin, the plug will only fit into a grounding-type power outlet. This is a safety feature. Do not defeat the safety purpose of the grounding-type plug. If your outlet does not have the grounding plug receptacle, contact your local electrician.

## 9. **CORD AND CABLE PROTECTION**

Route power cords and cables in a manner to protect them from damage by being walked on or pinched by items placed upon or against them.

## 10. **LIGHTNING**

For protection of the equipment during a lightning storm or when it is left unattended and unused for long periods of time, unplug the unit from the wall outlet. Disconnect any antennas or cable systems that may be connected to the equipment. This will prevent damage to the equipment due to lightning or power-line surges.

## 11. **OVERLOADING**

Do not overload wall outlets and extension cords as this can result in a risk of fire or electric shock.

## 12. **SERVICING**

Do not attempt to service the video monitor or equipment yourself as opening or removing covers may expose you to dangerous voltage or other hazards. Refer all servicing to qualified service personnel.

**13. DAMAGE REQUIRING SERVICE**

Unplug the equipment from the wall outlet and refer servicing to qualified service personnel under the following conditions:

- A. When the power supply cord or the plug has been damaged.
- B. If liquid has spilled or objects have fallen into the unit.
- C. If the equipment has been exposed to water or other liquids.
- D. If the equipment does not operate normally by following the operating instructions, adjust only those controls that are covered by the operating instructions. Improper adjustment of other controls may result in damage to the unit.
- E. If the equipment has been dropped or the casing damaged.
- F. When the equipment exhibits a distinct change in performance.

**14. REPLACEMENT PARTS**

When replacement parts are required, be sure the service technician uses replacement parts specified by the manufacturer or that have the same characteristics as the original part. Unauthorized substitutions may result in fire, electric shock, or other hazards.

**15. SAFETY CHECK**

Upon completion of any service or repairs to the equipment, ask the service technician to perform safety checks to verify that the equipment is in proper operating condition.

**16. FIELD INSTALLATION**

The installation of equipment should be made by a qualified service person and should conform to all local codes.

## TABLE OF CONTENTS

|   |    |
|---|----|
| INTRODUCTION.....                                 | 1  |
| SYSTEM INSTALLATION .....                         | 2  |
| CAMERA OVERVIEW.....                              | 4  |
| MANUAL IRIS LENS ADJUSTMENT .....                 | 6  |
| VIDEO AUTO IRIS INSTALLATION & ADJUSTMENT .....   | 7  |
| DC AUTO IRIS LENS INSTALLATION & ADJUSTMENT ..... | 9  |
| BACK FOCUS ADJUSTMENT .....                       | 11 |
| ZOOM LENS BACK FOCUS ADJUSTMENT .....             | 12 |
| TROUBLESHOOTING AND MAINTENANCE .....             | 13 |
| SPECIFICATIONS .....                              | 15 |

THIS PAGE INTENTIONALLY LEFT BLANK

# BLACK & WHITE CAMERAS STANDARD AND HIGH RESOLUTION

## INTRODUCTION

---

The Standard and High resolution black and white security cameras provides SONY quality images for use in closed circuit television (CCTV) and security surveillance applications.

### Features:

- High performance 1/3" Interline Transfer SONY CCD
- Resolution:     380 lines for Standard  
                  570 lines for High
- .08 lux @ F1.4 sensitivity
- Supports standard C or CS mount lenses
- Equipped with electronic iris
- Adapts to Video or DC auto iris lenses through dip switch setting
- Quick connection to auto iris lens with 4-pin connector
- AGC adjustment
- Include BLC function
- 12V DC power
- Two year warranty

# SYSTEM INSTALLATION

---

Installation of the camera must be performed by qualified service personnel in accordance with all local and national electrical and mechanical codes. Perform the following steps to install the camera.

1. Remove all components from the package and identify the items that will be used during installation.
  - The camera with the CS lens mount
  - Mini din connector (for Video and DC type auto iris lenses)
  - C mount ring
  - Instruction manual

Other items used during the installation that are NOT supplied with the camera may include:

- 12V DC power supply
  - Camera lens
  - Camera stand or mounting bracket
  - Video cable
  - Monitor
  - Mounting hardware
2. Select a suitable location for the camera. Install the camera stand or mounting bracket in the selected location using a suitable fastener. The camera stand or mounting bracket must be attached to a structural object, such as a wall stud or ceiling rafter, that supports the weight of the camera and mount. The minimum recommended load rating for the bracket is 5 kg (11 lbs).
  3. Attach the camera to the camera stand or mounting bracket using the hardware supplied with the stand. The hardware connects to the 1/4" – 20 UNC threaded mounting hole on the top and bottom of the camera housing.

Note: The mounting bracket on the camera housing can be attached to the top or bottom of the housing to accommodate various installation options.

4. Route the video cable from the monitor to the camera.
5. Plug the cable into the BNC output connector labeled "VIDEO OUT" on the back of the camera.

6. Plug the other end of the cable into the video input port on the back of the monitoring device.

**On 12V DC models:**

7. Connect a two-conductor power cable from the power supply to the 12V DC input on the back of the camera.

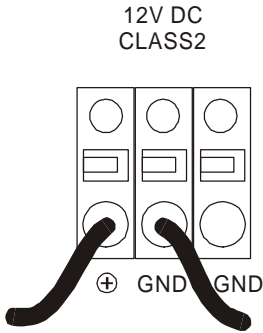

*Use a UL-listed Class 2 power transformer and a 12V DC power adapter. Use only a Class 2 power source.*

8. Apply 12V DC power to the camera.



## 2. Back Focus Lock Screw

The lock screw locks the back focus ring after adjusting.

## 3. Auto Iris Lens Connector

The auto-iris lens connector supplies either a video signal or DC control signal to an auto iris lens. A standard 4-pin din connector interfaces to any auto iris lens.

## 4. Mounting Bracket Hole

The threaded holes (1/4" – 20) are used to mount the camera onto a mounting bracket or tripod.

## 5. Function Switch

The functions of the dip switch settings are explained below.

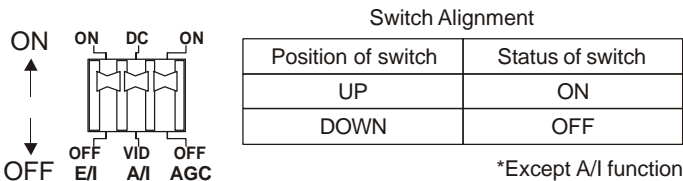

### A. E/I (Electronic Iris) (SW1)

The E/I automatically varies the camera's shutter to mimic auto iris control, allowing fixed or manual iris lenses to be used in a wider range of applications.

### B. A/I (Auto Iris) (SW2)

The A/I switch is used to select the appropriate auto iris control signal to the lens.

DC: Select for use with a DC auto iris lens

VID: Select for use with a video auto iris lens

| SWITCH POSITION | A/I SETTING | E/I SETTING |
|-----------------|-------------|-------------|
| UP              | DC          | OFF         |
| DOWN            | VIDEO       | OFF         |

### C. AGC (Auto Gain Control) (SW3)

The AGC feature keeps signals at a constant level. This control is useful when using the camera at low light levels or when light levels change over time.

## **6. LEVEL Adjustment**

The LEVEL control adjusts the level of the auto iris when the A/I lens selection switch is set to the DC position and a DC lens is mounted on the camera. The A/I switch should be in the “vid” position when a video type auto iris lens is used. The LEVEL adjustment does not apply to video type A/I lenses, only DC lenses.

## **7. Video Output Connector (BNC)**

A 1.0Vp-p, 75 ohm composite video signal is provided to this output connector.

## **8. Power Input Terminal (12V DC model)**

The power input terminal accepts 12V DC power from a UL listed Class 2 supply.

## **9. Power LED**

The green power LED illuminates when power is supplied to the camera.

## **MANUAL IRIS LENS ADJUSTMENT**

---

When using a manual iris lens, turn the iris ring on the lens to the OPEN position and adjust the manual iris for the appropriate range. Adjust during the brightest conditions, opening the lens to the minimum f-stop yielding a good picture under the brightest scene conditions. Do not saturate the picture.

The manual iris is used in indoor applications where lighting from windows can considerably affect the light level of the room.

# VIDEO AUTO IRIS INSTALLATION & ADJUSTMENT

The camera supports video-type auto iris lenses which adjust to changing light levels. Perform the following steps to install and adjust a video-type auto iris lens.

1. If necessary, solder the lens control wires to the connector supplied with the camera.

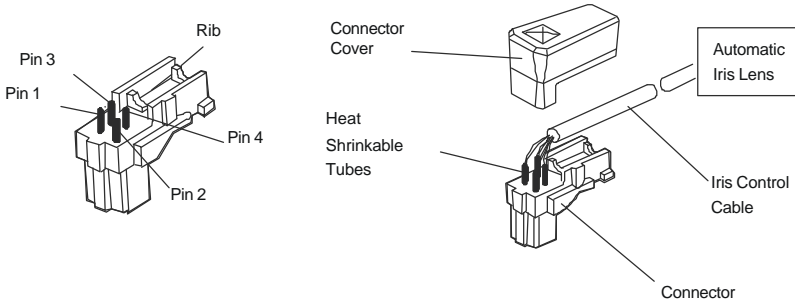

| PIN | NAME      | WIRE COLOR |
|-----|-----------|------------|
| 1   | Voltage + | Red        |
| 2   | Open      | -          |
| 3   | Video     | White      |
| 4   | Ground    | Black      |

2. Attach the video-type auto iris lens to the lens mount on the front of the camera.
3. Plug the connector from the lens into the auto iris jack on the back of the camera. The connector is polarized and can only be inserted into the jack one way.
4. The E/I switch should be in the "OFF" position.
5. The A/I switch should be in the "VID" position.
6. Apply power to the camera.
7. Adjust the focus ring on the lens for an optimum picture. If a picture is not visible, set the lens for proper exposure by adjusting the ALC (Automatic Level Control) and the level on the lens. The ALC setting can range between AVG (average) or PK (peak). A midrange setting is appropriate for most applications.

### **For ALC adjustments:**

- AVG** To slow the reaction of the lens to changing light, set the range to the AVG setting to average the video level from the camera. Use when there are bright spots in the picture such as lights or glare from the sun.
- PK** To increase the speed of the lens reaction to the changing light, set the lens adjustment to PK so the lens will adjust to the brightest or peak object in the video. Use this setting if you want to see the brightest object and not the background objects.

### **For Level adjustments:**

Adjust the level control for the best picture during the day. A night adjustment may not provide the proper setting for controlling the light during the day.

- 8.** Set the back focus of the camera before the final adjustment of the video level.
- 9.** If the auto iris has a gain adjustment and the picture oscillates between open and closed under bright lights, slowly turn the gain adjustment counter clockwise until the oscillating stops. Increase the light getting to the camera by adjusting the level control and re-adjusting the gain control.

# DC AUTO IRIS LENS INSTALLATION & ADJUSTMENT

The camera supports DC-type auto iris lenses. Perform the following steps to install and adjust a DC-type auto iris lens.

1. Solder the lens control wires to the connector supplied with the camera.

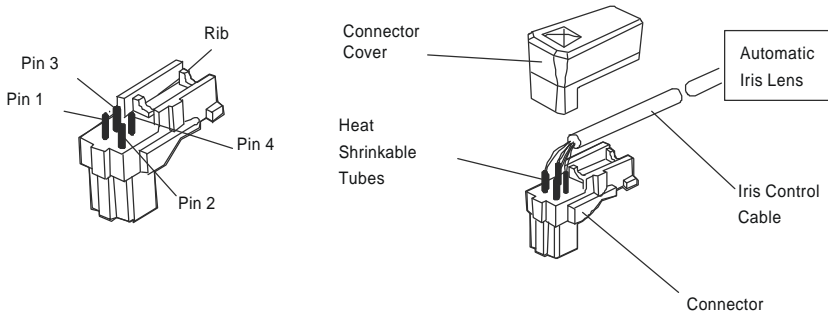

| PIN | NAME         | WIRE COLOR |
|-----|--------------|------------|
| 1   | Damp Coil -  | Blue       |
| 2   | Damp Coil +  | Red        |
| 3   | Drive Coil + | White      |
| 4   | Drive Coil - | Green      |

2. Attach the DC-type auto iris lens to the lens mount on the front of the camera.
3. Plug the connector into the auto iris jack on the back of the camera. The connector is polarized and can only be inserted into the jack one way.

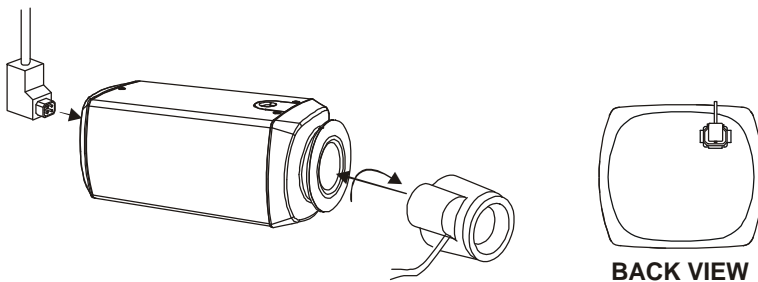

4. The E/I switch should be in the "OFF" position.
5. The A/I switch should be in the "DC" position.
6. Apply power to the camera.
7. Adjust the auto iris lens for an optimum picture using the LEVEL control on the back of the camera.

## **BACK FOCUS ADJUSTMENT**

---

For best results, perform back focus adjustments at night or while using a #6 or #8 welders glass in front of the lens. The focus of the camera will change slightly if the camera iris was adjusted on a light scene, then changes to a dark scene. However, the camera will remain in focus if the iris was focused on a dark scene and the scene lightens.

1. The lens should be mounted on the camera before applying power.
2. If a picture is visible, focus on the picture. If the picture is not visible, open the iris on the lens. Open the lens as wide as possible by placing the welder's glass in front of the lens and forcing the lens to automatically open.
3. When the iris is open to the widest point, re-adjust the focus for clear picture. If a clear picture is not possible, set the focus ring to midrange.
4. Loosen the back focus lock screw.
5. Adjust the back focus ring for a clear picture.
6. Tighten the back focus lock screw.
7. Fine tune the focus with the focus ring on the lens.
8. Remove the welder's glass from in front of the lens.
9. Adjust the iris of the lens for the best picture quality.

## **ZOOM LENS BACK FOCUS ADJUSTMENT**

---

The objective of back focusing a zoom lens is similar to that of a fixed focal length camera except the back focus is also adjusted to maintain the focus when “zooming” the lens in and out on a scene.

1. Choose an object at the farthest range set for viewing with a zoom lens.
2. Make sure the iris of the lens is wide open. Do this by adjusting the camera at night or use a welders glass in front of the lens.
3. Adjust the focus to the stop on the far range.
4. Adjust the zoom on the lens to obtain the widest picture.
5. Loosen the back focus lock screw.
6. Adjust the back focus ring for the clearest picture.
7. Tighten the back focus lock screw.
8. Adjust the zoom on the lens to the far telephoto position.
9. Adjust the back focus ring for the clearest picture.
10. Adjust the zoom on the lens back to the widest picture.
11. Loosen the back focus screw.
12. Re-adjust the back focus for the clearest picture.
13. Tighten the back focus lock screw.
14. Repeat the previous steps as necessary to maintain a clear picture throughout the entire zoom range.

# TROUBLESHOOTING AND MAINTENANCE

---

## Troubleshooting

If problems occur, verify the installation of the camera with the instructions in this manual and with other operating equipment. Isolate the problem to the specific piece of equipment in the system and refer to the equipment manual for further information.

| <b>PROBLEM</b>       | <b>AREA TO CHECK</b>  |
|----------------------|---|
| No Video             | <ol style="list-style-type: none"><li>1. Verify power is applied to all pieces of the equipment in the system. The camera LED should be ON.</li><li>2. Verify that the video cables are connected correctly.</li><li>3. Verify that the lens cap has been removed from the lens and the iris of the lens is open.</li></ol> |
| Video but no control | Power down the system for one minute then re-apply power.   |
| Dark Video           | <ol style="list-style-type: none"><li>1. Adjust iris.</li><li>2. Check A/I connections.</li></ol>   |

## Preventive Maintenance

Preventive maintenance allows detection and correction of minor faults before they become serious and cause equipment failures.

Every three months perform the following maintenance:

1. Inspect all connecting cables for deterioration or other damage.
2. Clean components with a clean damp cloth.
3. Verify that all mounting hardware is secure.

THIS PAGE INTENTIONALLY LEFT BLANK.

# SPECIFICATIONS

---

## **Power**

|                   |              |
|-------------------|--------------|
| Power source      | 12V DC       |
| Power consumption | Max. 4 Watts |

## **Sensor Information**

|                        |  |
|------------------------|--|
| Image sensor           | 1/3" CCD (SONY)  |
| Chip size              | 6.0mm (H) x 4.96mm (V)   |
| Picture element        | Standard: 510 (H) x 492 (V) EIA<br>500 (H) x 582 (V) CCIR<br>High: 768 (H) x 494 (V) EIA<br>752 (H) x 582 (V) CCIR |
| Scanning system        | 2:1 interlace  |
| Scanning frequency     | 15.75 KHz, 60 Hz EIA<br>15.625 KHz, 50 Hz CCIR   |
| Sync system            | Internal   |
| Electronic shutter     | 1/60 ~ 1/100,000 sec EIA<br>1/50 ~ 1/100,000 sec CCIR  |
| Temperature / Humidity | 14° F to 122° F (-10° C to 50° C), < 96%   |

## **Video**

|                      |   |
|----------------------|---|
| Signal format        | 525 lines EIA / 625 lines CCIR              |
| Resolution           | Standard: 380 TV lines / High: 570 TV lines |
| Minimum illumination | 0.08 Lux                                    |
| Video output         | 1.0Vp-p, 75 ohms                            |
| S/N ratio            | 50dB (AGC OFF)                              |
| BLC size             | 40% center                                  |
| Sync level           | 40 IRE(EIA), 300mV(CCIR)                    |
| Electronic iris      | On/Off selectable                           |
| Auto iris            | Video / DC selectable                       |
| BLC                  | On fixed                                    |
| AGC                  | On/Off selectable                           |
| DC iris level        | Adjustable                                  |

## **Connectors & Mechanical**

|                     |   |
|---------------------|---|
| Video output        | BNC connector                             |
| Power input         | 3-pin terminal block at 12V DC model      |
| Auto iris connector | 4-pin mini din                            |
| Lens mount          | C or CS mount                             |
| Mounting hole       | 1 / 4" - 20 UNC top and bottom            |
| Dimensions          | 2.4W x 2.1H x 5.0D" (62W x 54H x 127D mm) |
| Weight              | 225g at 12V DC                            |

## **BLACK AND WHITE CAMERA**

1/3" CCD  
STANDARD RESOLUTION  
HIGH RESOLUTION

50301420A