

IMPORTANT SAFEGUARDS

1. **READ INSTRUCTIONS** – All of the safety and operating instructions should be read before the appliance is operated.
2. **RETAIN INSTRUCTIONS** – The safety and operating instructions should be retained for future reference.
3. **HEED WARNINGS** – All warnings on the product and in the operating instructions should be adhered to.
4. **FOLLOW INSTRUCTIONS** – All operating and use instructions should be followed.
5. **CLEANING** – Unplug this product from the wall outlet before cleaning. Do not use liquid cleaners or aerosol cleaners. Use a damp cloth for cleaning the EXTERIOR CASE ONLY.
6. **ATTACHMENTS** – Do not use attachments not recommended by the product manufacturer as they may result in the risk of fire, electric shock, or injury to persons.
7. **WATER AND MOISTURE** – Do not use this product equipment near water – for example, near a bathtub, washbowl, kitchen sink, laundry tub, in a wet basement, or near a swimming pool – or near moist or damp areas.
8. **ACCESSORIES** - Do not place this product on an unstable cart, stand, tripod, bracket, or table. The product may fall, causing serious injury to a child or adult and serious damage to the equipment. Use only with a cart, stand, tripod, bracket, or table recommended by the manufacturer, or sold with the product. Any mounting of the product should follow the manufacturer's instructions and should use a mounting accessory recommended by the manufacturer. Wall or shelf mounting should follow the manufacturer's instructions and should use a mounting kit approved by the manufacturer.
9. A product and cart combination should be moved with care. Quick stops, excessive force, and uneven surfaces may cause the product and cart combination to overturn. 
10. **VENTILATION** - Slots and openings in the cabinet and the back or bottom are provided for ventilation and to ensure reliable operation of the equipment and to protect it from overheating. These openings must not be blocked or covered. The openings should never be blocked by placing the product on a bed, sofa, rug, or other similar surface. Equipment should never be placed near or over a radiator or heat register. This product should not be placed in a built-in installation, such as a bookcase or rack unless proper ventilation is provided or the manufacturer's instructions have been adhered to.
11. **POWER SOURCES** – This product should be operated only from the type of power source indicated on the marking label. If you are not sure of the type of power supplied to your home, consult your product dealer or local power company. For products designed to operate from battery power or other sources, refer to the operating instructions.
12. **GROUNDING OR POLARIZATION** – This product is equipped with a polarized alternating-current line plug (a plug having one blade wider than the other). This plug will fit into the power outlet only one way. This is a safety feature. If you are unable to insert the plug fully into the outlet, try reversing the plug. If the plug should still fail to fit, contact your electrician to replace your obsolete outlet. Do not defeat the safety purpose of the polarized plug.

Alternatively, this unit may be equipped with a 3-wire grounding-type plug, a plug having a third (grounding) pin. This plug will only fit into a grounding-type power outlet. This is a safety feature. If you are unable to insert the plug into the outlet, contact an electrician to replace the obsolete outlet. Do not defeat the safety purpose of the grounding-type plug.
13. **POWER CORD PROTECTION** – Power-supply cords should be routed so that they are not likely to be walked on or pinched by items placed on them or against them, paying particular attention to cords at plugs and at point of exit from the product. Do not damage the power cord. Damage to the power cord may cause a fire or shock hazard. When unplugging the power cord, hold it by the plug and remove it carefully.

IMPORTANT SAFEGUARDS, CONTINUED

14. **OUTDOOR ANTENNA GROUNDING** – If an outside antenna or cable system is connected to the product, be sure the antenna or cable system is grounded so as to provide some protection against voltage surges and built-up static charges.
15. **LIGHTNING** – For added protection for this product during a lightning storm or when it is left unattended and unused for long periods of time, unplug it from the wall outlet and disconnect the antenna or cable system. This will prevent damage to the video product due to lightning and power-line surges.
16. **POWER LINES** – An outside antenna system should not be located in the vicinity of overhead power lines or other electric light or power circuits, or where it can fall into such power lines or circuits. When installing an outside antenna system, extreme care should be taken to keep from touching such power lines or circuits as contact with them might be fatal.
17. **OVERLOADING** – Do not overload wall outlets and extension cords as this can result in a risk of fire or electric shock.
18. **SERVICING** – Do not attempt to service this product yourself as opening or removing covers may expose you to dangerous voltage or other hazards. Refer all servicing to qualified service personnel.
19. **OBJECT AND LIQUID ENTRY** – Never push objects of any kind into this equipment as they may touch dangerous voltage points or short-out parts that could result in a fire or electric shock. Never spill liquid of any kind on the product.
20. **DAMAGE REQUIRING SERVICE** - Unplug the product from the wall outlet and refer servicing to qualified service personnel under the following conditions:
 - A. When the power supply cord or the plug has been damaged.
 - B. If liquid has spilled or objects have fallen into the video product.
 - C. If the product has been exposed to rain or water.
 - D. If the product does not operate normally by following the operating instructions, adjust only those controls that are covered by the operating instructions. Improper adjustment of other controls may result in damage and will often require extensive work by a qualified technician to restore the product to its normal operation.
 - E. If the product has been dropped or the cabinet damaged.
 - F. When the video product exhibits a distinct change in performance.
21. **REPLACEMENT PARTS** – When replacement parts are required, be sure that the service technician uses replacement parts specified by the manufacturer or that have the same characteristics as the original part. Unauthorized substitutions may result in fire, electric shock, or other hazards.
22. **SAFETY CHECK** – Upon completion of any service or repairs to this product, ask the service technician to perform safety checks to determine that the product is in proper operating condition.
23. **HEAT** – The product should be situated away from heat sources such as radiators, heat registers, stoves, or other products (including amplifiers) that produce heat. Use only in a well-ventilated area.
24. **FIELD INSTALLATION** – This installation should be made by a qualified service person and should conform to all local codes.
25. **ACCESSORY INPUTS** – Only use dry contact type switches as triggering devices/inputs to the security terminal. Introducing voltage to the event or panic record inputs may cause damage to the recorder as well as the device being connected. EOT (End of Tape) devices must observe polarity and limit DC voltage to 15 volts. Current consumption of an EOT device must be limited to 100mA or less. All connections to the rear screw terminal must be free of an AC component signal and RF noise. Shielded cable should be used for trigger input cable runs over 25 ft. in length.
26. **WALL OR CEILING MOUNTING** – The product should be mounted to a wall or ceiling only as recommended by the manufacturer.

WARNING

- THE VCR IN THIS SYSTEM IS NOT DESIGNED TO BE WATERPROOF. EXPOSURE TO WATER MAY DAMAGE THE UNIT.

CAUTION

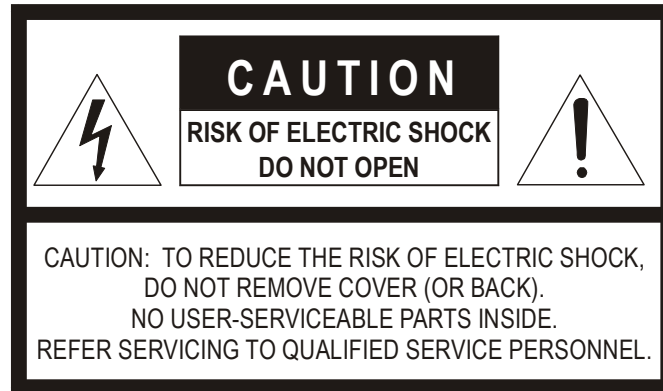

EXPLANATION OF GRAPHICAL SYMBOLS



The lightning flash with arrowhead symbol, within an equilateral triangle, is intended to alert the user to the presence of uninsulated "dangerous voltage" within the product's enclosure that may be of sufficient magnitude to constitute a risk of electric shock to persons.



The exclamation point within an equilateral triangle is intended to alert the user to the presence of important operating and maintenance (servicing) instruction in the literature accompanying the product.

USERS OF THE PRODUCT ARE RESPONSIBLE FOR CHECKING AND COMPLYING WITH ALL FEDERAL, STATE, AND LOCAL LAWS AND STATUTES CONCERNING THE MONITORING AND RECORDING OF VIDEO AND AUDIO SIGNALS.

TABLE OF CONTENTS

SECTION 1: SCHOOL BUS VIDEO OBSERVATION SYSTEM	1
1.1 PRODUCT DESCRIPTION	1
1.2 ABOUT THIS MANUAL	1
1.3 ADDITIONAL INFORMATION ABOUT THIS PRODUCT	1
“Live” vs. “Dummy” Systems	1
SECTION 2: INSTALLATION	2
2.1 SYSTEM WIRING.....	2
2.2 LOCKBOX MOUNTING.....	4
2.3 VCR INSTALLATION	6
2.4 CAMERA INSTALLATION.....	8
2.5 SYSTEM TESTING	10
SECTION 3: SYSTEM OPERATION.....	11
3.1 INTRODUCTION	11
3.2 STOP/EJECT.....	11
3.3 VCR PROGRAMMING	12
3.4 SET LANGUAGE.....	12
3.5 SET TIME/DATE.....	13
Time and Date	13
Date Format.....	13
Daylight Savings.....	13
Display Location	14
Bus ID Title	14
3.6 SET RECORD FEATURES	14
Repeat Record.....	14
EP Record Mode	15
Power Off Delay.....	15
No Video-Out Warning	15
No Signal- Warning	15
3.7 SET DISPLAY FEATURES	16
Speed Format.....	16
Temp Cut-Off.....	17
Drum Elapsed Time.....	17
Audio Channel	17
3.8 DEFINE INPUT FEATURES	18
3.9 CALIBRATE SPEEDOMETER.....	19
SECTION 4: TROUBLESHOOTING AND MAINTENANCE.....	20
4.1 TROUBLESHOOTING	20
4.2 PREVENTIVE MAINTENANCE.....	21
SECTION 5: WARRANTY	22

SECTION 6: SPECIFICATIONS.....	23
6.1 VCR	23
6.2 CAMERA	24

LIST OF TABLES

Table 1: Connections to main VCR wiring harness.....	2
Table 2: Connections to record brake, stop, and warning indicators	2
Table 3: Connections to record bus speed.....	3
Table 4: Default Inputs.....	18
Table 5: Available Input Values	18

LIST OF FIGURES

Figure 1: Enclosure Mounting Locations	4
Figure 2: Screw Keyholes in the VCR Lockbox.....	5
Figure 3: Connections from Camera to VCR.....	6
Figure 4: Connections on Front and Back	7
Figure 5: Strap Installation.....	7
Figure 6: Camera Mounting	8
Figure 7: Connections on the front	11
Figure 8: Main Menu.....	12
Figure 9: Set Language	12
Figure 10: Main Menu	13
Figure 11: Time and Date Menu.....	13
Figure 12: Set Date Format	13
Figure 13: Set Recorder Features	14
Figure 14: Recorder Features Menu	14
Figure 15: EP Record Mode	15
Figure 16: Set Display Features	16
Figure 17: Display Features Menu	16
Figure 18: Define Input Features	18
Figure 19: Calibrate Speedometer	19
Figure 20: Begin/Cancel Calibration.....	19
Figure 21: Calibration Process	19
Figure 22: Calibration Complete.....	19

THIS PAGE INTENTIONALLY LEFT BLANK.

SECTION 1: SCHOOL BUS VIDEO OBSERVATION SYSTEM

1.1 PRODUCT DESCRIPTION

The 12V dc VHS recording system is specially designed for use in a school bus as both a video and audio recorder. Unlike camcorders, the VCR is wired into the vehicle's electrical system and can be powered for long periods by a 12V battery without causing any damage.

NOTE: *All electronics in this system are designed to meet rugged automotive service standards, with protection against over voltage, reverse battery connections and two battery jump starts.*

1.2 ABOUT THIS MANUAL

Please read this manual carefully to fully understand the installation and operation of this system before proceeding with the installation.

This manual was written with the technician in mind. It is strongly recommended that components be installed in the order described in this manual: the main VCR wiring harness into the electrical system of the bus, the lockbox, the VCR, then the camera. Installation and operating instructions for this system should be fully read and understood before proceeding with installation.



IMPORTANT: Failure to follow these installation instructions completely could void your warranty and possibly lead to system malfunction or electrical short.

1.3 ADDITIONAL INFORMATION ABOUT THIS PRODUCT

“Live” vs. “Dummy” Systems

Regardless of whether you purchased a “live” or “dummy” system, the installation of the components is virtually the same. Like the “live” system, the “dummy” system also comes with a complete wiring harness that connects with the bus' electrical system, as well as a lockbox.

The “dummy” camera also features a flashing red indicator light as if it were an operating camera. “Dummy” systems, however, do not come with a VCR or operational camera. A “dummy” system can easily be converted to a “live” system in minutes by installing a VCR and a “live” camera.

SECTION 2: INSTALLATION

2.1 SYSTEM WIRING

1. Disconnect the battery from the electrical system of the bus before proceeding to wire the system.

2. Once the battery has been safely disconnected from the bus, make the appropriate connections to the main VCR wiring harness as follows:

RED	Connect the red wire to the positive (+) terminal of the battery.
BLACK	Connect the black wire to the negative (-) terminal of the battery.
GRAY	Connect the gray wire to the ignition circuit, after the ignition switch. Confirm that voltage is a consistent 12-14V dc.

Table 1: Connections to main VCR wiring harness

	<p>IMPORTANT: Follow these directions carefully to make the appropriate connections safely. Connect the fused main red power wire directly to the positive battery terminal. Connect the black ground wire directly to the negative battery terminal. Do not bypass or change the value of the inline fuse. Doing so can result in damage to the system and may void your warranty.</p>
--	--

3. In order to record brake, stop, emergency door, and warning indicators on videotape, make the following connections:

Note: Any of the wires can be assigned to any of the warning indicators.
See Section 3.8: Define Input Features.

GREEN	Connect the green wire to a source that is hot (12V dc) when the yellow hazard lights are activated.
YELLOW	Connect the yellow wire to a source that is hot (12V dc) when the brake lights are activated.
WHITE	Connect the white wire to a source that is hot (12V dc) when the stop arm is activated.
BROWN	Connect the brown wire to a source that is hot (12V dc) when the emergency door is opened.

Table 2: Connections to record brake, stop, and warning indicators

2.1 SYSTEM WIRING, CONTINUED

- The following connections must be made in order to record the speed of the bus.

NOTE: *Disregard this step if you did not purchase the optional Speed sensor. See instructions for setting SPEED DISPLAY in Section 3.7 to activate the speedometer display function.*

ORANGE	Connect the orange wire to the red wire coming from the speedometer sensor harness.
BLUE	Connect the blue wire to the white wire coming from the speedometer sensor harness.
PURPLE	Connect the purple wire to the black wire coming from the speedometer sensor harness.

Table 3: Connections to record bus speed

- Feed the end of the main VCR harness through the bus to the approximate location where the VCR and lockbox will be installed. This cable can be routed behind header and trim panels. Be sure to leave slack in the cable before finalizing the installation of the harness.

NOTE: *The cable that runs from the battery to the VCR is 30-feet long.*

NOTE: *When the system is installed, check all of the cable to ensure all strain has been relieved.*

2.2 LOCKBOX MOUNTING

1. Find a suitable place to install the VCR lockbox. The base of the lockbox should be securely installed flush against a flat surface.

NOTE: *The cable that runs from the VCR to the battery is 30-feet long.
 The cable from the VCR to the ignition switch, speedometer sensor, and brake, stop and warning connections is 20-feet long.
 The wiring harness that runs from the VCR to the camera is 20-feet long.*

	<p>IMPORTANT: We do not recommend that the lockbox be mounted vertically. If the lockbox must be mounted vertically, ensure that it is located with the door facing up.</p>
---	--



MOUNTING OPTIONS:	
<p>1. On the floor</p> <div style="text-align: center; margin-top: 20px;">  </div>	<p>2. On the underside of a seat.</p> <div style="text-align: center; margin-top: 20px;">  </div> <p style="text-align: center;">Secure the VCR so that it is bottom-side up.</p>
<p>3. In a vertical position, only if the VCR is mounted with the VCR door facing up. The box should have a spacer placed at the bottom to give it at least a 10 degree angle towards the horizontal position to ensure proper performance of the tape transport assembly.</p> <div style="display: flex; justify-content: space-around; margin-top: 20px;"> <div style="text-align: center;">  </div> <div style="text-align: center;">  </div> </div> <p style="text-align: center; margin-top: 10px;">This mounting option should be used only when necessary.</p>	

Figure 1: Enclosure Mounting Locations

2.2 LOCKBOX MOUNTING, CONTINUED

1. Mount the lockbox base.
The base is attached to the surface using four screws (*not provided*) and metal washers (*provided*) through the holes in located on the bottom of the base. (See Figure 2).

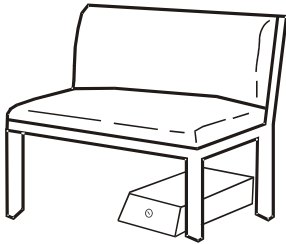
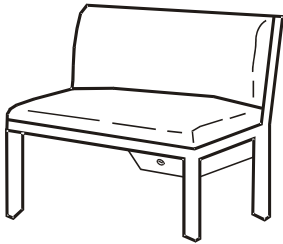
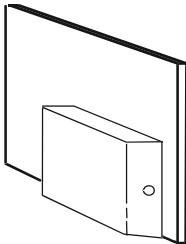
NOTE: We strongly recommend that you check to make sure that the front door of the lockbox opens and closes freely before securing the base to the chosen surface.
To locate the screw holes, open the lockbox with the supplied key and remove the top half of the lockbox.

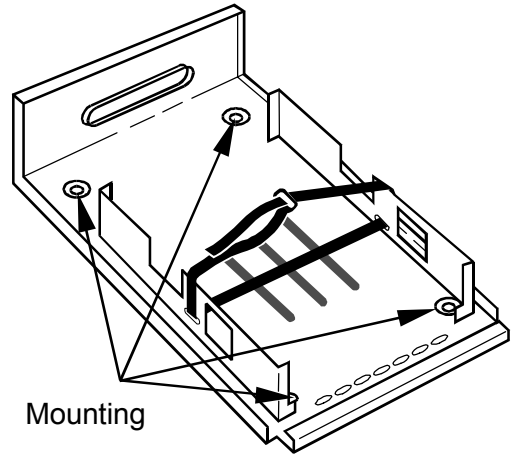

Figure 2: Screw Keyholes in the VCR Lockbox

- Hold the bottom plate of the lockbox against the mounting surface and mark each of the holes.
- Remove the base of the lockbox from the desired surface. Using the marks, drill holes for screws through the selected surface.

	<p>IMPORTANT: Before drilling, be sure to check the underside of the surface for any obstructions that should not be drilled through.</p>
--	--

2.3 VCR INSTALLATION

1. Feed the main VCR wiring harness and the camera wiring harness through the slot on the back of the lockbox. (See Figure 4.)
2. Plug each connector from the camera wiring harness, which includes two RCA-type plugs and a barrel connector, into the back of the VCR as shown in Figures 3 and 4. If necessary, use the adapter cable to connect the camera to the VCR.
3. Connect the 2.1mm barrel plug to the 12-14V dc port located on the front of the VCR.
4. Insert the 25-pin D-sub connector plug into the appropriate input on the back of the VCR and tighten the thumbnuts. (See Figures 4 and 5.)

NOTE: You can make full use of the Hi-Fi Stereo function of your VCR. It is possible to record sound from both the Front of the bus (camera side) and Rear of the bus (Mic) at the same time.

Connecting directly from camera to VCR (or to adapter cable if needed).

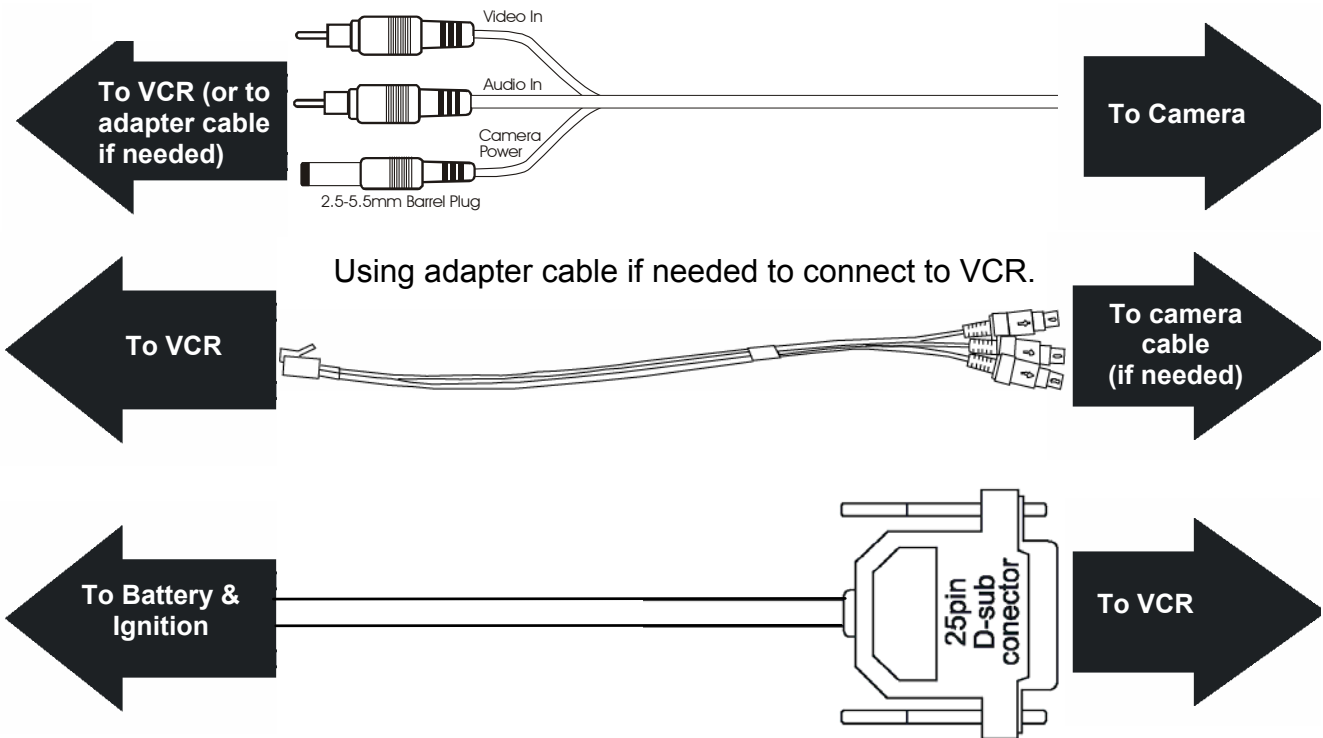

Figure 3: Connections from Camera to VCR

2.3 VCR INSTALLATION, CONTINUED

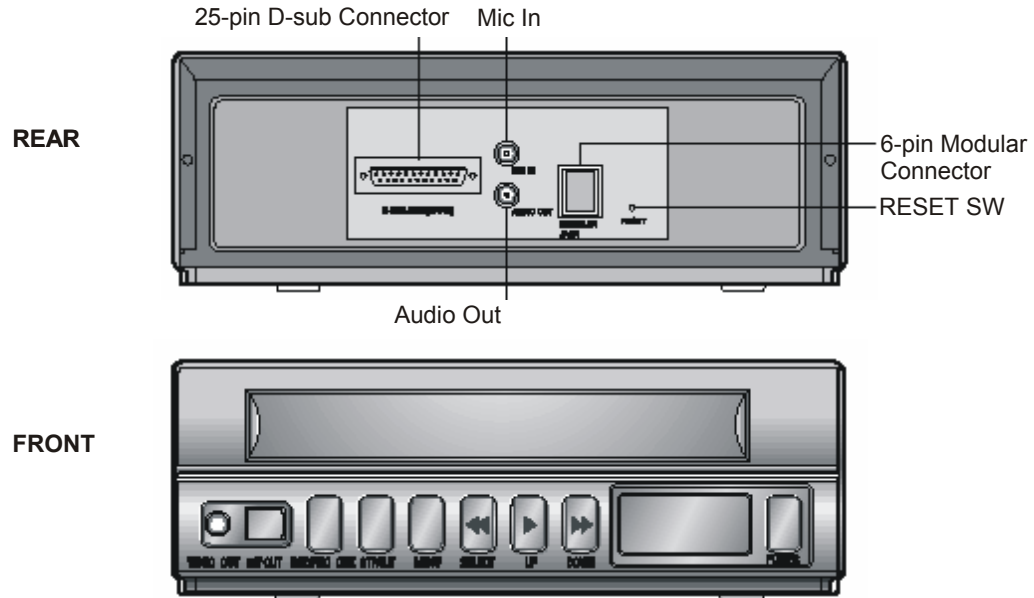

Figure 4: Connections on Front and Back

5. Grasp the strap attached to the lockbox base and open it. Lay each end of the strap over its respective side of the base. (See Figure 5.)
6. With the front of the VCR toward the open end of the lockbox base, place the VCR right side up onto the foam strips. The housing fits the VCR very snugly to prevent vibration.
7. Bring each end of the strap over the VCR, feeding one end through the loop on the other. Pull the strap tight and fasten so the VCR will not shake loose.

NOTE: If you have mounted the lockbox to the underside of a seat or other object, you may need help holding the VCR in place while securing the strap.

8. Slide the lockbox covering over the lockbox base until secure.

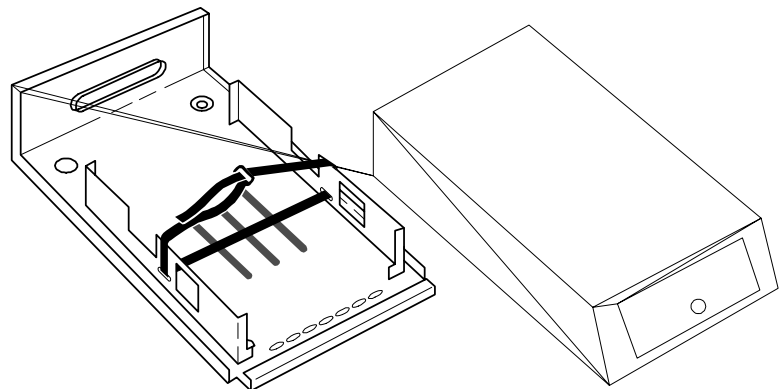

Figure 5: Strap Installation

2.4 CAMERA INSTALLATION

1. Feed the camera wiring harness from the VCR lockbox to the approximate location where the camera will be installed. The wiring harness can be run through wiring conduit if desired, and the cable can be routed behind header panels and trim panels.

NOTE: When choosing an appropriate location for camera installation, take into consideration that the cord that runs from the camera to the VCR is approximately 20-feet long.

2. Locate the camera and bracket in the desired position. Secure the bracket on a flat surface of the bus.
3. Plug the camera cable into the camera and tighten the connection with the screws provided. (See Figure 6.) Use the provided security allen wrench to tighten the camera at the desired angle.

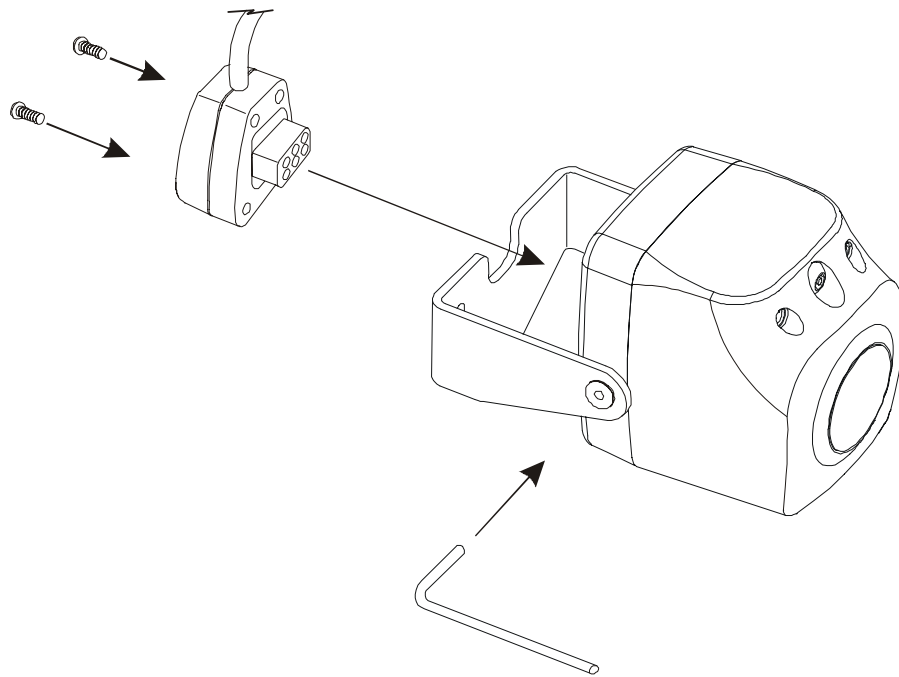

Figure 6: Camera Mounting

2.4 CAMERA INSTALLATION, CONTINUED

4. To ensure optimal placement of the camera for proper viewing, connect a monitor (*not included*) to the VCR. Plug one end of the RCA cable (*not provided*) into the VIDEO OUT port on the front of the VCR.
5. **Without turning on the bus ignition switch**, turn on the video observation and recording system by pressing the POWER button on the front of the VCR. (This will provide you with approximately 60 seconds of power.) If there is a video tape in the VCR, remove it by pressing the STOP/EJECT button.
6. Turn on the monitor, which should display the image captured by the camera.
7. Find a place to mount the camera that provides the best view of the area to be monitored. Typically, a central location on the front header panel or roof works best.

NOTE: Remember when positioning the camera and bracket that the cord to the VCR is 25-feet long.

8. Using an assistant, hold the camera and bracket in place on the mounting surface while viewing the monitor. Move the camera and bracket to locate the appropriate position.
9. Once you have found the best position for the camera and bracket, disconnect the camera from the terminal block.
10. Using the three bracket holes as a guide, mark the bracket placement onto the selected surface.
11. Remove the bracket from the surface and drill three holes corresponding to the marks.
12. Position the bracket over the holes and secure to the mounting surface using a Phillips screwdriver and the supplied mounting screws.
13. Reconnect the camera to the terminal block. Secure the assembly by tightening the screw located on the back. (*See Figure 6.*)
14. Adjust the vertical position of the camera to achieve the best view.
15. Lock the camera position securely with the provided security screw and allen wrench.

2.5 SYSTEM TESTING

Once all of the system components are installed, the system is ready for testing.

1. With the bus ignition in the OFF position, press the POWER button on the VCR once. This will activate the “momentary power” feature on the VCR causing it to power-up for 60 seconds to allow you to insert a VHS tape. This momentary power feature of your VCR will also enable retrieval of the tape from the VCR without using the keys to the bus ignition.
2. Insert the videotape.
3. Turn on the ignition to the bus. The VCR should begin recording.

NOTE: *If the system does not operate properly, see the Troubleshooting section.*

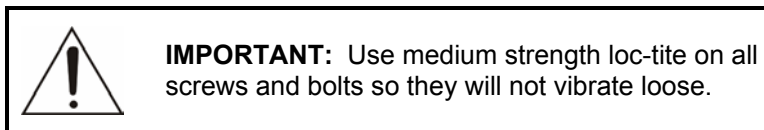

4. Record Check: Press PLAY during recording and the VCR will rewind to playback three seconds of the recent recording. The VCR will then return to Record Mode. (There is no audio during Record Check playback.)

SECTION 3: SYSTEM OPERATION

3.1 INTRODUCTION

Most users will only need to change the time and date twice a year and will use the factory default values for other programming. In the event that your system needs reprogramming, please follow the instructions below.

3.2 STOP/EJECT

1. Press the STOP/EJECT button twice to enter the Stop Mode. If the VCR is in the Record Mode and the STOP/EJECT button is pressed, the VCR will continue to record. To stop the recorder, the STOP/EJECT button must be pressed again. Pressing the STOP/EJECT button once the recorder is in the Stop Mode will eject the tape.
2. The VCR does not automatically go into Record Mode from the Stop Mode. Press REC to enter the Record Mode.

NOTE: This VCR was designed for recording purposes. It will start recording on ignition, unless starting from the Stop Mode and not until the programmed POWER OFF delay time expires. If you insert a tape without a safety tab, the VCR will wait for the next key input. If the REC button is pushed, the VCR will eject the tape.

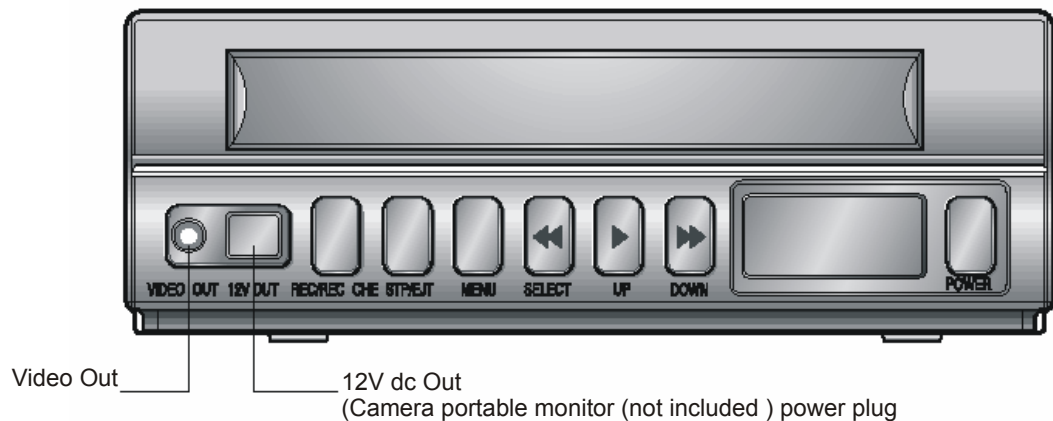

Figure 7: Connections on the front.

3.3 VCR PROGRAMMING

With the system connected, power on, and a cable running from the VIDEO OUT plug on the VCR to the VIDEO IN plug on the monitor, the monitor should display the image captured by the camera. The time, date, and several other features should also be displayed at the bottom of the screen.

There are seven buttons on the front of the VCR with four used to program the system.

- SEL button advances through the functions and changes initial data.
- UP and DOWN buttons are used to increase or decrease a number or alphabet and move the cursor up or down lists.
- The MENU button is used to call the setup menu.

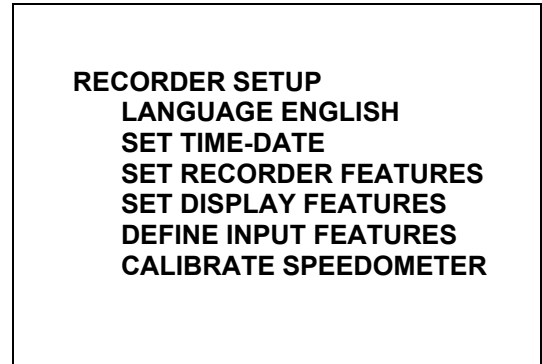

Figure 8: Main Menu

1. Press the MENU button once to display the Main Menu on the monitor (See Figure 8). There should be a cursor next to the first topic, "LANGUAGE."

NOTE: Pressing the UP and DOWN buttons will take you through the cycle of option modes on the menu, and the cursor indicates which topic is queued. Pressing the SEL button allows you to enter a specific topic in order to check the settings.

2. Using the SEL and UP or DOWN buttons, program the system to meet the appropriate specifications as described in the following pages of Section 2.

3.4 SET LANGUAGE

This VCR allows the user to select English or Spanish as the language used for on-screen displays.

1. With the cursor at the LANGUAGE function, pressing the SEL button will toggle between ENGLISH and SPANISH.
2. Use the DOWN button to lock the selection and move to the next feature.

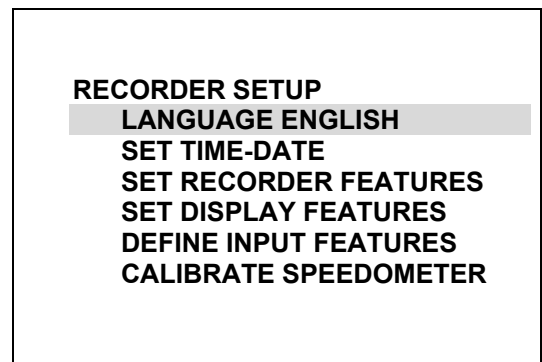

Figure 9: Set Language

3.5 SET TIME/DATE

Time and Date

The SET TIME-DATE menu is used to set preferences for the time and date options for the recorder. Month, day, and year are displayed according to date format selected.

1. Press SEL to program TIME/DATE. Press SEL to move to number display. Use the UP or DOWN buttons to change the digits. When the correct digits are showing, press SEL to move to the next field.
2. The field requiring programming should be flashing.
3. Press SEL again to move to the next field.
4. Continue with remaining fields using the UP and DOWN keys to change the value and SEL to enter the value:
 - Month
 - Day
 - Year
 - Hour
 - Minutes
 - Seconds

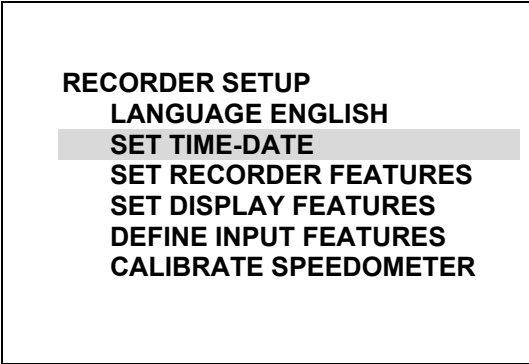

```
RECORDER SETUP
LANGUAGE ENGLISH
SET TIME-DATE
SET RECORDER FEATURES
SET DISPLAY FEATURES
DEFINE INPUT FEATURES
CALIBRATE SPEEDOMETER
```

Figure 10: Main Menu

TIME AND DATE

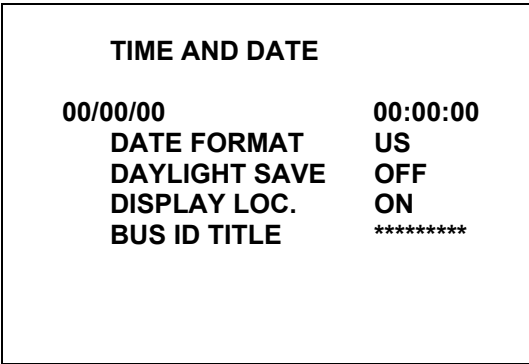

```
00/00/00          00:00:00
DATE FORMAT      US
DAYLIGHT SAVE   OFF
DISPLAY LOC.    ON
BUS ID TITLE     *****
```

Figure 11: Time and Date Menu

Date Format

The DATE FORMAT feature allows the user to determine how dates will be displayed.

1. With the cursor at DATE FORMAT, press SEL to choose the proper date format.
2. Press the DOWN button to lock selection and move to the next feature.

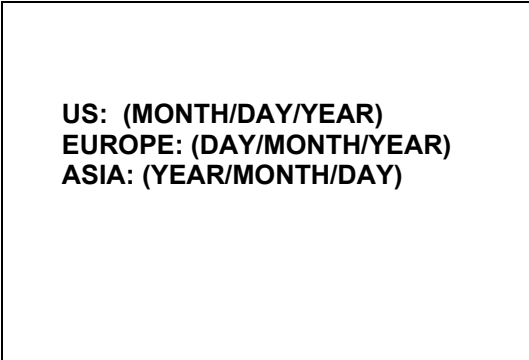

```
US: (MONTH/DAY/YEAR)
EUROPE: (DAY/MONTH/YEAR)
ASIA: (YEAR/MONTH/DAY)
```

Figure 12: Set Date Format

Daylight Savings

DAYLIGHT SAVINGS is used to determine whether the clock will apply adjustments for daylight savings time to the time settings.

1. With the cursor at DAYLIGHT SAVE, press SEL to toggle between ON and OFF settings.
2. Use the DOWN button to lock the selection and move to the next feature.

3.5 SET TIME/DATE, CONTINUED

Display Location

1. With the cursor at DISPLAY LOC., press SEL to toggle between ON and OFF settings.
2. Use the DOWN button to lock the selection and move to the next feature.

NOTE: The display position is set to lower left and cannot be changed.
The options for Display Location are ON or OFF.

Bus ID Title

BUS ID TITLE allows a title to identify the bus being recorded.

1. With the cursor at the BUS ID TITLE field, press SEL.
2. Use the UP and DOWN buttons to select a character, then press SEL.
Repeat these steps for all required characters (maximum: 10 characters).

3.6 SET RECORD FEATURES

From the Main Menu, press UP or DOWN until SET RECORD FEATURES is queued by the cursor, then press SEL. The RECORD FEATURES screen will appear. (See Figure 14).

Note: Camera LED warning will work only with specific cameras.

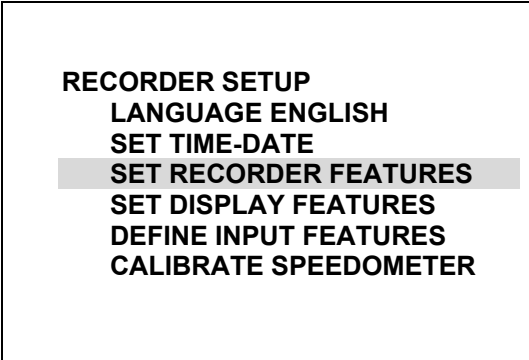

```
RECORDER SETUP
LANGUAGE ENGLISH
SET TIME-DATE
SET RECORDER FEATURES
SET DISPLAY FEATURES
DEFINE INPUT FEATURES
CALIBRATE SPEEDOMETER
```

Figure 13: Set Recorder Features

Repeat Record

When REPEAT RECORD is ON, the videotape automatically rewinds once it reaches the tape end and begins recording over the previously taped footage.

When REPEAT RECORD is OFF, the unit does not repeat the record cycle. At tape end, the tape will rewind to the beginning and power down the VCR. This is useful in securing tape contents once the tape is full. To continue recording, the tape will need to be ejected and a new (rewound) tape will need to be inserted or the used tape can be reinserted to be recorded over.

RECORDER FEATURES



```
REPEAT RECORD      OFF
EP RECORD MODE     ON
POWER OFF DELAY    3MIN
NO VIDEO-OUT WARN  ON
```

Figure 14: Recorder Features Menu

1. With the cursor at REPEAT RECORD, press SEL to toggle between ON and OFF.
2. Press the DOWN button to lock in your selection and advance to the next feature.

IMPORTANT: If using this feature, replace the tape every two months due to wear.

3.6 SET RECORD FEATURES, CONTINUED

EP Record Mode EP (Extended Play) Record Mode allows longer recording on tapes.

When EP Record Mode is ON, a T-120 tape allows up to 6 hours of continuous recording and a T-160 tape allows up to 8 hours.

When EP Record Mode is OFF, the VCR operates in SP (Standard Play) Mode. In SP Mode, a T-120 tape allows up to 2 hours of continuous recording and a T-160 tape allows for 2.67 hours recording.

TAPE	SP MODE	EP MODE
	“OFF”	“ON”
T120	2 Hr	6 Hr
T160	2.67 Hr	8 Hr

Figure 15: EP Record Mode

1. With the cursor at EP Record Mode, press SEL to toggle between ON and OFF.
2. Press the DOWN button to lock in your selection and advance to the next feature.

Power Off Delay POWER OFF DELAY allows the system to maintain power for 0 to 20 minutes after the ignition has been turned off.

1. With the cursor at POWER OFF DELAY, press SEL to advance the number of minutes.
2. Press the DOWN button to lock in your selection and advance to the next feature.

No Video-Out Warning NO VIDEO-OUT WARNING is a visual signal that alerts the operator that the VCR has stopped recording due to a malfunction or an end of tape condition. The LED will display a solid light at the camera if either of these conditions occurs.

If NO VIDEO-OUT WARN is ON, the LED will flash to indicate that the VCR is recording properly to the video input signal

If NO VIDEO-OUT WARN is OFF, the LED on the camera continues to blink.

1. With the cursor at NO VIDEO-OUT WARN, press SEL to toggle between ON and OFF.
2. Press the DOWN button to lock in your selection and advance to the next feature.

No Signal-Warning NO SIGNAL WARNING causes the VCR to display “No S” in case of camera malfunction or faulty camera cable connection when the recorder is in the Record mode. If “No S” is seen on the VCR, check camera and camera cable for malfunction.

3.7 SET DISPLAY FEATURES

From the Main Menu, press UP or DOWN until SET DISPLAY FEATURES is queued by the cursor, then press SEL.

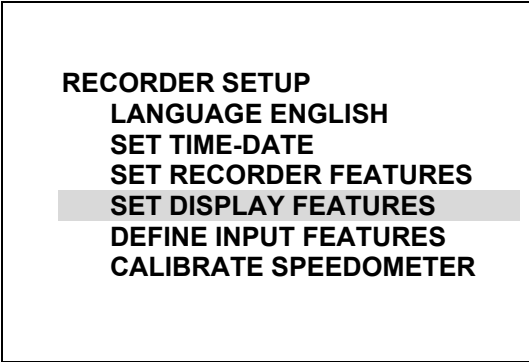

RECORDER SETUP
LANGUAGE ENGLISH
SET TIME-DATE
SET RECORDER FEATURES
SET DISPLAY FEATURES
DEFINE INPUT FEATURES
CALIBRATE SPEEDOMETER

Figure 16: Set Display Features

Speed Format

SPEED FORMAT selects KPH or MPH to display speed.

1. With the cursor at SPEED FORMAT, press SEL to toggle between KPH and MPH.
2. Press the DOWN button to lock in your selection and advance to the next feature.



DISPLAY FEATURES

SPEED FORMAT	MPH
CUT-OFF	ON
DRUM ELAPSED	000H
AUDIO CHANNEL	CAM

Figure 17: Display Features Menu

3.7 SET DISPLAY FEATURES, CONTINUED

Temp Cut-Off

TEMP CUT-OFF allows you to choose the temperature and humidity operational ranges of the VCR. When activated, this function tells the observation system not to turn itself on until the temperature range is 40°F to 120°F and the humidity range is 95% or below in the bus, as gauged inside the VCR.

1. With the cursor at CUT-OFF, press SEL to toggle between ON and OFF.
2. Press the DOWN button to lock in your selection and advance to the next feature.

Drum Elapsed Time

The DRUM ELAPSED function is used to automatically calculate the head use time in play and Record Mode.

1. View the DRUM ELAPSED time on the VCR LED display by pressing CLK/CNT/HR button on the remote control. The display will toggle through the clock, counter, and drum elapsed time, in that order.

Audio Channel

AUDIO CHANNEL can be specified as the camera or microphone.

1. With the cursor at AUDIO CHANNEL, press SEL to select camera (CAM) or microphone (MIC).
2. Press the DOWN button to lock in your selection and advance to the next feature.

NOTE: Both microphone and camera are always recorded. The Audio Channel option selects the recorded audio that is monitored during playback.

3.8 DEFINE INPUT FEATURES

This feature allows the user to change the indicator message displayed for each input trigger.

RECORDER SETUP
LANGUAGE ENGLISH
SET TIME-DATE
SET RECORDER FEATURES
SET DISPLAY FEATURES
DEFINE INPUT FEATURES
CALIBRATE SPEEDOMETER

Figure 18: Define Input Features

Default inputs:

PIN NO	WIRE COLOR	INDICATOR	CONTROLS
5	BROWN	EMD	EMERGENCY DOOR
7	WHITE	STP	STOP ARM
8	YELLOW	BRK	BRAKE
9	GREEN	WRN	AMBER WARNING LIGHTS

Table 4: Default Inputs

These inputs can be changed to one of the following:

These indicators can be assigned to any wire color.

INDICATOR	CONTROLS
BRK	BRAKE
EMD	EMERGENCY DOOR
HZD	HAZARD LIGHTS
LTS	LEFT TURN SIGNAL
LFT	LIFT (WHEELCHAIR ACCESSIBLE)
RVR	REVERSE
RTS	RIGHT TURN SIGNAL
STB	STROBE LIGHT
STP	STOP ARM
WRN	AMBER WARNING LIGHTS

Table 5: Available Input Values

3.9 CALIBRATE SPEEDOMETER

The proper speedometer format must be selected to obtain an accurate reading during calibration (see Section 3.7).

From the main menu, use the UP or DOWN buttons to move the cursor to CALIBRATE SPEEDOMETER and press SELECT.

Instructions will appear.

1. To begin calibration, press SEL.
A new screen will appear.

To cancel calibration, press MENU.

2. At the end of one mile, press SEL.
Increasing counts will be stopped to the screen. Calibration is complete.

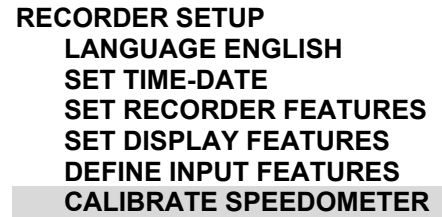

RECORDER SETUP
LANGUAGE ENGLISH
SET TIME-DATE
SET RECORDER FEATURES
SET DISPLAY FEATURES
DEFINE INPUT FEATURES
CALIBRATE SPEEDOMETER

Figure 19: Calibrate Speedometer



CALIBRATE SPEEDOMETER
PRESS SELECT TO BEGIN
PRESS MENU TO CANCEL

(SELECT) (MENU)

Figure 20: Begin/Cancel Calibration

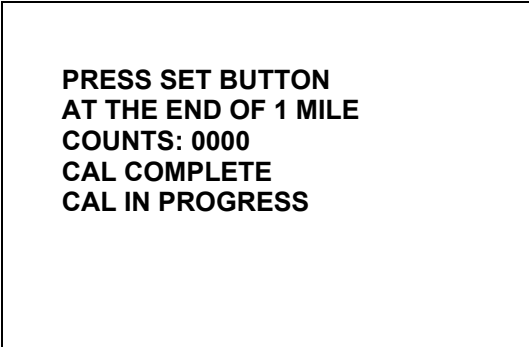

PRESS SET BUTTON
AT THE END OF 1 MILE
COUNTS: 0000
CAL COMPLETE
CAL IN PROGRESS

Figure 21: Calibration Process



COUNTS: 4875
CAL COMPLETE

Figure 22: Calibration Complete

SECTION 4: TROUBLESHOOTING AND MAINTENANCE

4.1 TROUBLESHOOTING

If you experience operating difficulties, refer to the following.

PROBLEM	CHECK
No power	<p>There can be several reasons the unit does not seem to power up. First, check the 3-amp, ATO external fuse. If the fuse is blown, replace it with another 3 Amp ATO fuse.</p> <div style="border: 1px solid black; padding: 5px; margin: 10px 0;">  <p>WARNING: Never, under <u>any</u> circumstances, replace this fuse with a fuse of any value other than 3 amp.</p> </div> <p>Check to make sure that all of the connectors are in place. Be sure that none of the pins on any of the connectors are bent. (Remove each connector from the back of the VCR for inspection). The only connector that may not be connected when using a live system is the barrel plug off of the front panel.</p>
No Recording	<p>Check that the tape record-protect tab is intact and has not been removed. This tab is on the left side of the tape on the edge that goes in the VCR last. If the tab is broken, you cannot record on the tape.</p> <p>Make sure all connections are correct.</p> <p>Check the VCR for “No S” indicating that there is no signal coming from the camera to the VCR. Check the camera and cable for malfunctions and faulty connections</p>
No Video Output to Monitor	<p>Check to make sure that the video connection is secure between the VIDEO OUT port on the back of the VCR and the VIDEO IN jack on the back of the monitor. The monitor being used must also have an input for a composite video signal.</p> <p>Make sure the monitor is set to receive input from the VIDEO IN port. This setting is sometimes accessed using the televisions remote control. You may need to refer to the owners manual for the monitor.</p>
Snowy Video	<p>If your playback VCR doesn't have auto-tracking, manually adjust the tracking of the VCR.</p> <p>Use a non-abrasive video head cleaner to clean the playback VCR as well as the system VCR.</p>

4.2 PREVENTIVE MAINTENANCE

Following the preventive maintenance schedule allows detection and correction of minor faults before they become serious and cause equipment failure.

1. Clean the tape head regularly (every 60 days) with a commercial VCR tape head cleaner.
2. If you use the Automatic Repeat Record feature, throw tapes away after 60 days.
3. For higher quality video and audio, but less recording time, change the EP Record Mode from ON to OFF.
4. Replace the fuse only with a 3-Amp fuse
5. Under no circumstances should you open the unit. There are no user serviceable parts inside.

SECTION 6: SPECIFICATIONS

6.1 VCR

GENERAL	
Deck	4 Video Heads
Power Input	12V dc
Program	Battery Backup (3 months)
REC/PB	
REC System	Continuous
REC Mode	SP, EP(LP)
Audio	2 channels
OSD FEATURES	
	OSD Menu Date & Time Location: Display window and on-screen LED (seven-segment)
SPECIAL PLAYBACK FEATURES	
	Record Check Repeat REC Auto tracking
CONVENIENCE	
	Real Time Counter Head Hours Used Date Format (US/Europe/Asia) Text Generation (up to 10 characters) Daylight Savings Feature
CONNECTIONS	
Video In/Out	DB-25 pin/RCA
Audio In/Out	Molex(RJ-11)/RCA
Audio In/Out	Yes (Camera LED)
MIC	Yes
Reset	Yes
Remote Control	Wireless (optional)
H.Resolution	More than 245 lines (color)
Video S/N	45dB
Audio S/N	42dB

6.2 CAMERA

POWER	
Power Source	12V dc (from VCR)
Power Consumption	3.0W max.
GENERAL	
LED	RED (VCR detector)
Image Sensor	1/3" interline transfer CCD (Sony)
Picture Element	512(H) x 3.7mm(V)
Chip Size	4.9H x 3.7V mm
Unit Cell Size	9.6H x 7.5V μ m
Scanning System	2:1 interlace
Scanning Frequency	15.734KHz(H), 59.94Hz (V)
Operating Temperature	14°F to 122°F (-10°C to 50°C)
Sync System	Internal
Electronic Shutter	1/60 ~ 1/100,000 sec.
Lens Spec	4mm, 6mm, 8mm
VIDEO	
Audio Output	600 Ohms line level
Signal Format	NTSC and PAL
Resolution	Color: 330 TV lines / Black-and-White: 380 TV lines
Minimum Illumination	Color: 2 lux (F2.0) / Black-and-White: 0.1 lux (F3.8)
Video Output	1.0Vp-p, 75 Ohms
S/N Ratio	46dB (AGC off)
BLC	60% center (BLC on)
AGC	ON/OFF selectable
CONNECTOR & MECHANICAL	
Video Output	6-pin molex
Lens Mount	Fixed mount
PHYSICAL	
External Dimensions	3.6W x 2.1H x 3.5D inches (92W x 54H x 90D mm)
Weight	2 lbs. (900g)